

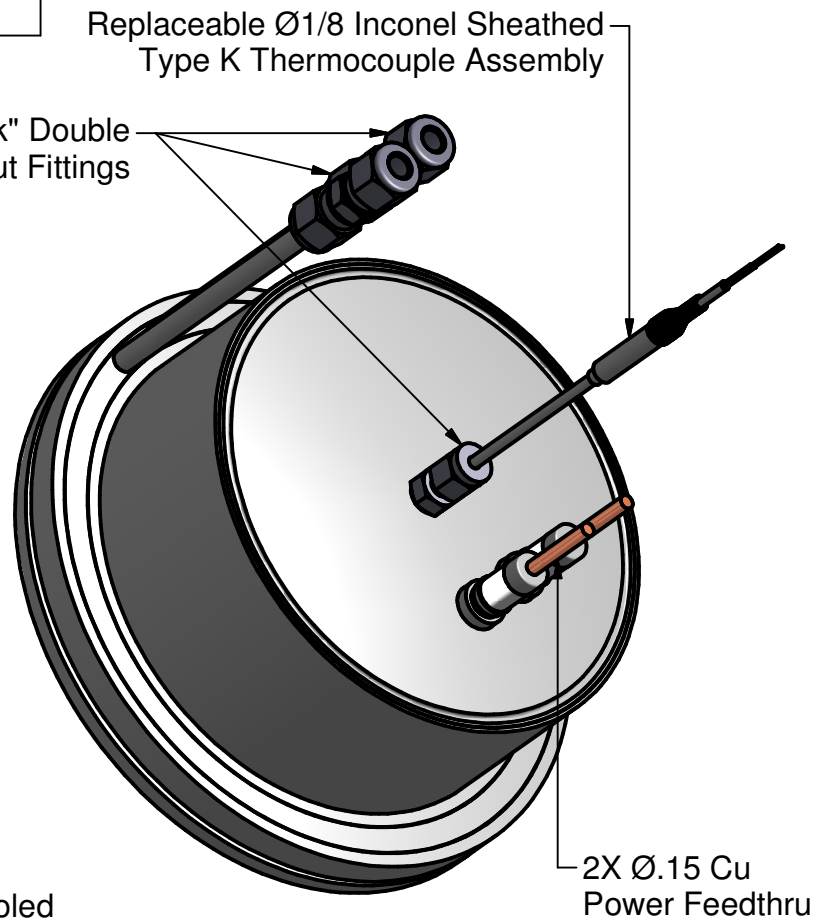

PARTS LIST

ITEM	QTY	PART NUMBER	DESCRIPTION
1	1	107456	6" Flange Mounted UHV Heater, BOM

This document is the property of HeatWave Labs. Its contents may not be reproduced without express written permission of HeatWave Labs.

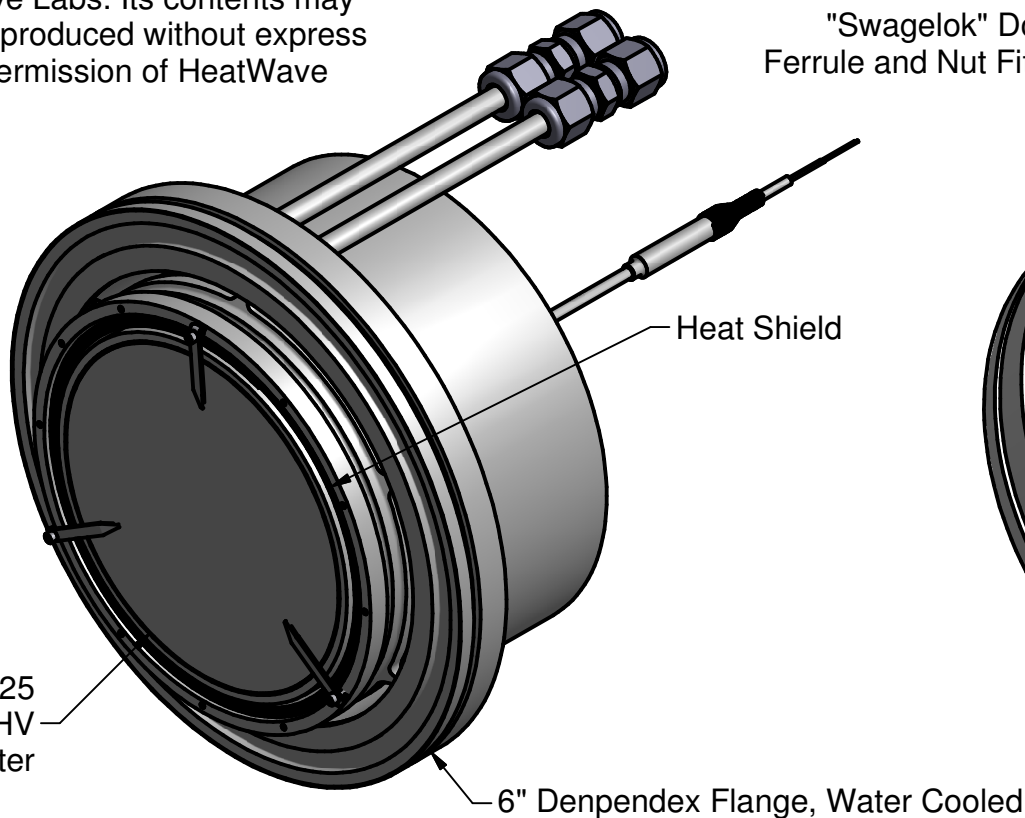

Notes:

- Estimated operation:
 11.3V, 20.1A @ 800 °C
 13.8V, 22.9A @ 1000 °C
 18.2V, 27.5A @ 1200 °C
- The assembly must be leak tight to 1×10^{-9} cc/sec Helium.
- This assembly is supplied with the diffusor plate and the heavy sample mounting plate.
- A set of six support legs have been added to the housing from support during use with a heavy sample.

DRAWN	mcurtis	1/13/2012
CHECKED		
QA		
MFG		
APPROVED		
Material:		

HeatWave Labs, Inc. 195 Aviation Way, Suite 100 P: 831-722-9081
 Watsonville, CA 95076 F: 831-722-5491
 www.cathode.com

**6" Dendex Flange Mounted
 Ø4.0 UHV Heater Assembly**

SIZE	Cage Code:	DWG NO	REV
A	1YAN4	107338	
SCALE	1/2		SHEET 1 OF 4



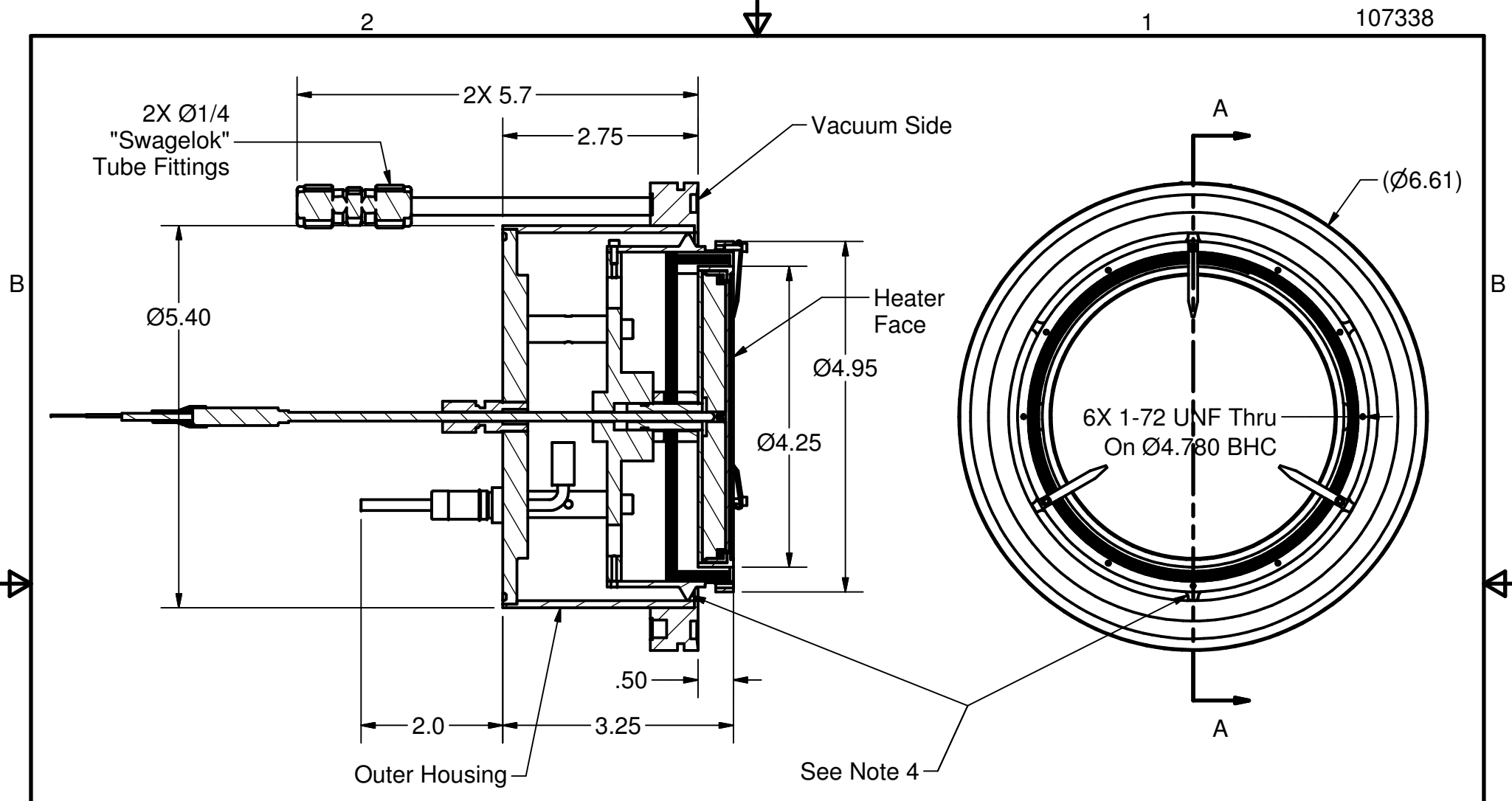

SECTION A-A
SCALE 1 / 2

See Note 4

This document is the property of HeatWave Labs. Its contents may not be reproduced without express written permission of HeatWave Labs.

DRAWN mcurtis	1/13/2012
CHECKED	
QA	
MFG	
APPROVED	

<i>HeatWave Labs, Inc.</i>		195 Aviation Way, Suite 100 P: 831-722-9081 Watsonville, CA 95076 F: 831-722-5491 www.cathode.com	
6" Dependex Flange Mounted Ø4.0 UHV Heater Assembly			
SIZE A	DWG NO 107338	REV	
SCALE 1/2	SHEET 2 OF 4		



6X Slots to Help with Thermal Isolation

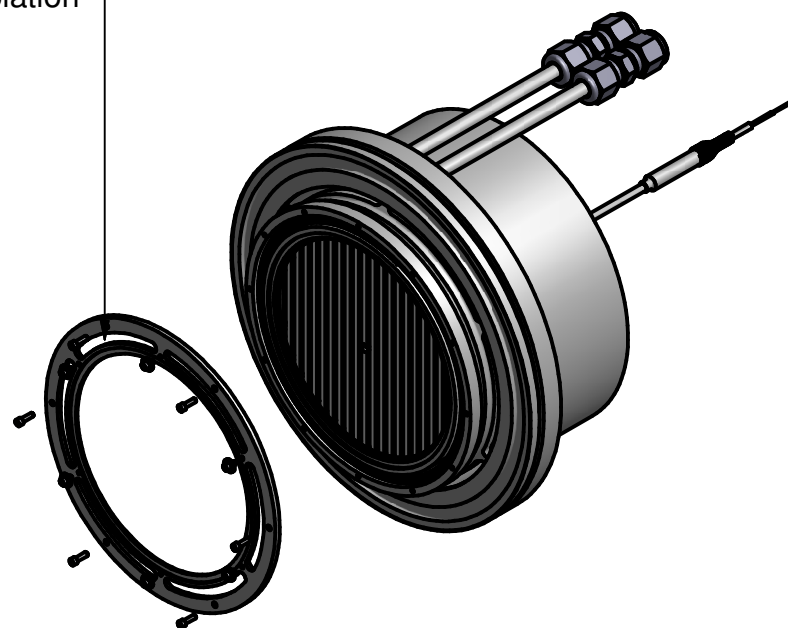
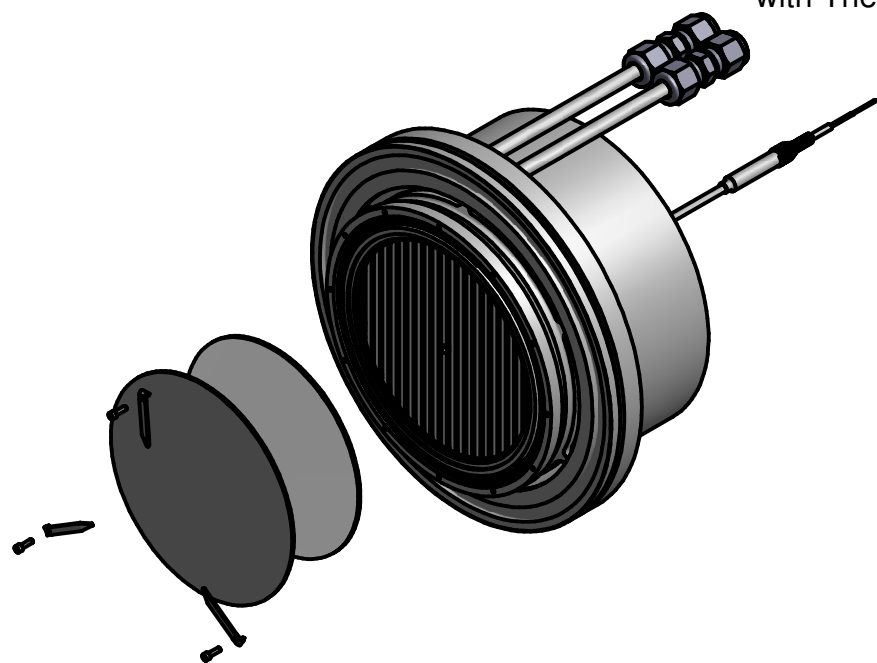

This View Shown with Diffusor Plate, Insulating Disc, SST Screws and Sample Clips Removed

This View Shown with Heavy Sample Mount, SST Screws and Washers Removed

B

B



A

A

This document is the property of HeatWave Labs. Its contents may not be reproduced without express written permission of HeatWave Labs.

DRAWN mcurtis	1/13/2012
CHECKED	
QA	
MFG	
APPROVED	

HeatWave Labs, Inc. 195 Aviation Way, Suite 100 P: 831-722-9081
 Watsonville, CA 95076 F: 831-722-5491
 www.cathode.com

6" Dependex Flange Mounted
Ø4.0 UHV Heater Assembly

SIZE A	DWG NO 107338	REV
SCALE 1/3	SHEET 3 OF 4	



2

1

.15 Gap Between Filament
and Back Surface of Sample

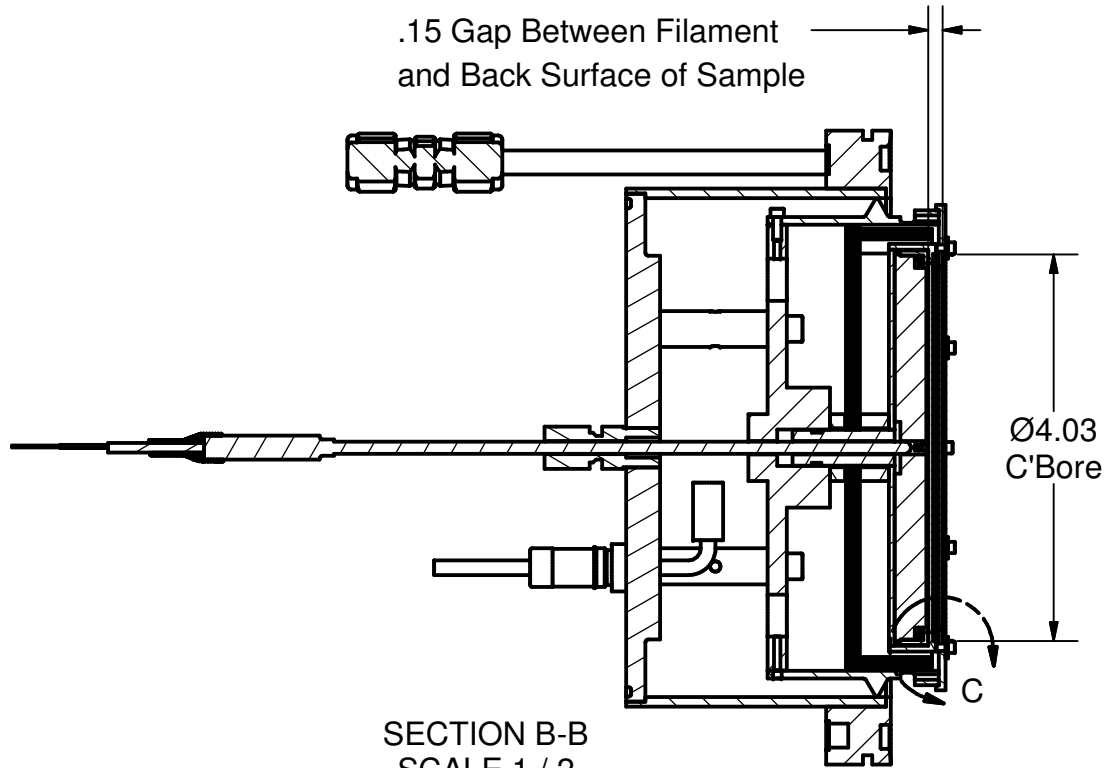

SECTION B-B
SCALE 1 / 2

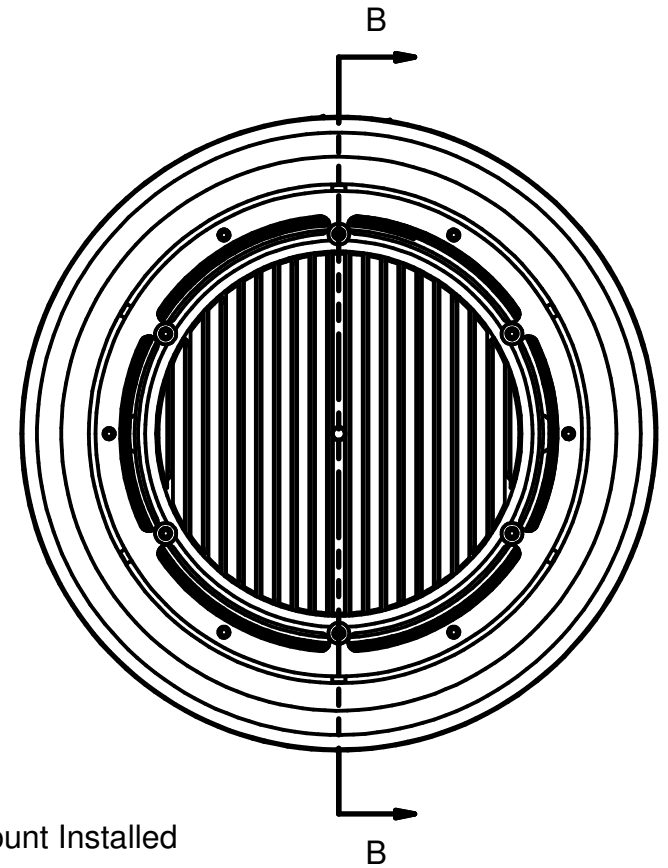

These Views Show the Heavy Sample Mount Installed

This document is the property of HeatWave Labs.
Its contents may not be reproduced without
express written permission of HeatWave Labs.

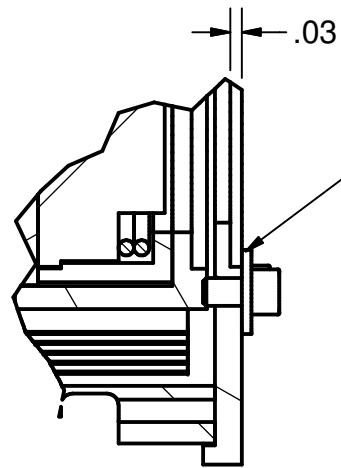

Customer Ø4.0 Sample Plate
Held in Place by SST Washers

DETAIL C
SCALE 2 : 1

DRAWN mcurtis	1/13/2012
CHECKED	
QA	
MFG	
APPROVED	

<i>HeatWave Labs, Inc.</i>		195 Aviation Way, Suite 100 P: 831-722-9081 Watsonville, CA 95076 F: 831-722-5491 www.cathode.com	
6" Dependex Flange Mounted Ø4.0 UHV Heater Assembly			
SIZE A	DWG NO 107338	REV	
SCALE 1/2	SHEET 4 OF 4		

2

1