



PARTS LIST

ITEM	QTY	PART NUMBER	DESCRIPTION
1	1	106568	Ø2.0 O2 Heater Assembly, BOM

Ø2.0 O2 Heater Assembly

Front Heat Shield Shown w/Cutout to Allow TC Position & Ø1.00 Thru

TC Position Adjustment Screw, Shown w/TC .50 Off Center

Front TC, Type K, Inconel Sheathed, Not Grounded, Ø1/16 x 4.0 with Termination and Flying Leads x 12.0, Teflon Insulated

Spring Loaded TC Clamp

Internal Type "K" TC Flying Leads, x 6.0 Minimum

2X Power Termination

B

B



A

A

DRAWN mcurtis	11/15/2010
CHECKED	
QA	
MFG	
APPROVED	
Material:	
-	

HeatWave Labs, Inc.
 195 Aviation Way, Suite 100 P: 831-722-9081
 Watsonville, CA 95076 F: 831-722-5491
 www.cathode.com

Ø2.0 O2 Heater Assembly w/Front Heat Shield & 2X TC

This document is the property of HeatWave Labs. Its contents may not be reproduced without express written permission of HeatWave Labs.

SIZE A	Cage Code: 1YAN4	DWG NO 106561	REV
SCALE 1x	1		SHEET 1 OF 2



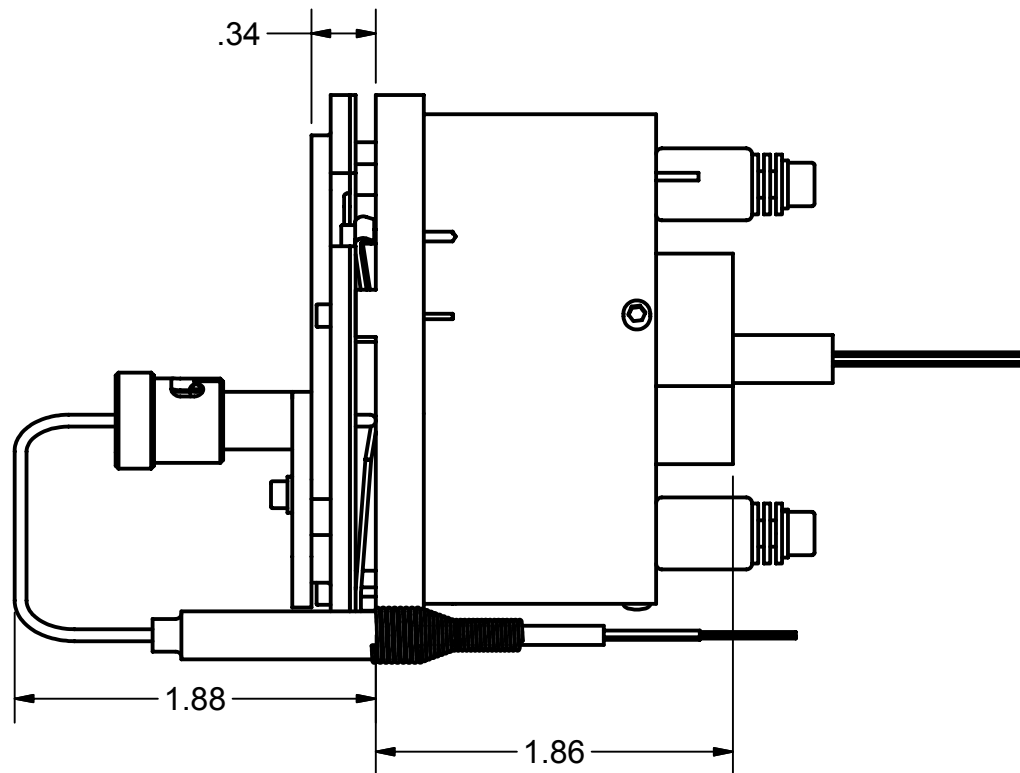
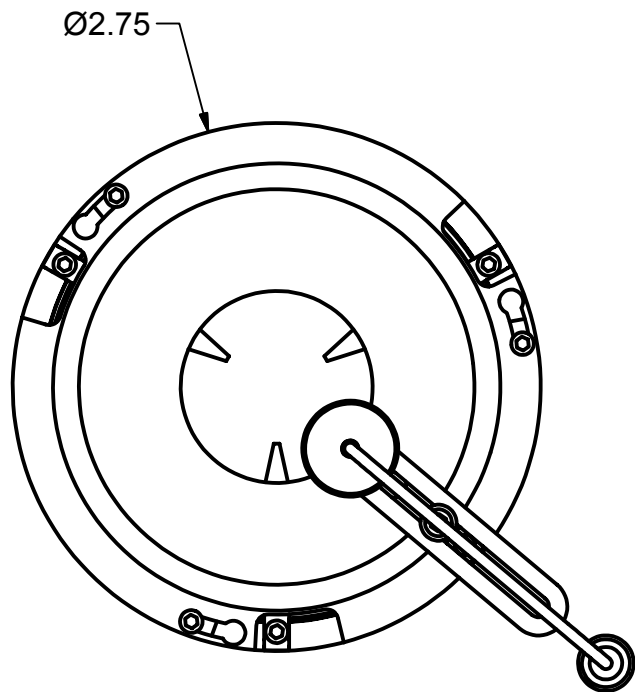

B

B

A

A

This document is the property of HeatWave Labs. Its contents may not be reproduced without express written permission of HeatWave Labs.

DRAWN mcurtis	11/15/2010
CHECKED	
QA	
MFG	
APPROVED	

HeatWave Labs, Inc.		195 Aviation Way, Suite 100 P: 831-722-9081 Watsonville, CA 95076 F: 831-722-5491 www.cathode.com	
Ø2.0 O2 Heater Assembly w/Front Heat Shield & 2X TC			
SIZE A	DWG NO 106561	REV	
SCALE 1x	SHEET 2 OF 2		