

REVISION HISTORY

REV	DESCRIPTION	DATE	APPROVE
A	Power leads where Kapton insulated.	2/1/10	MC

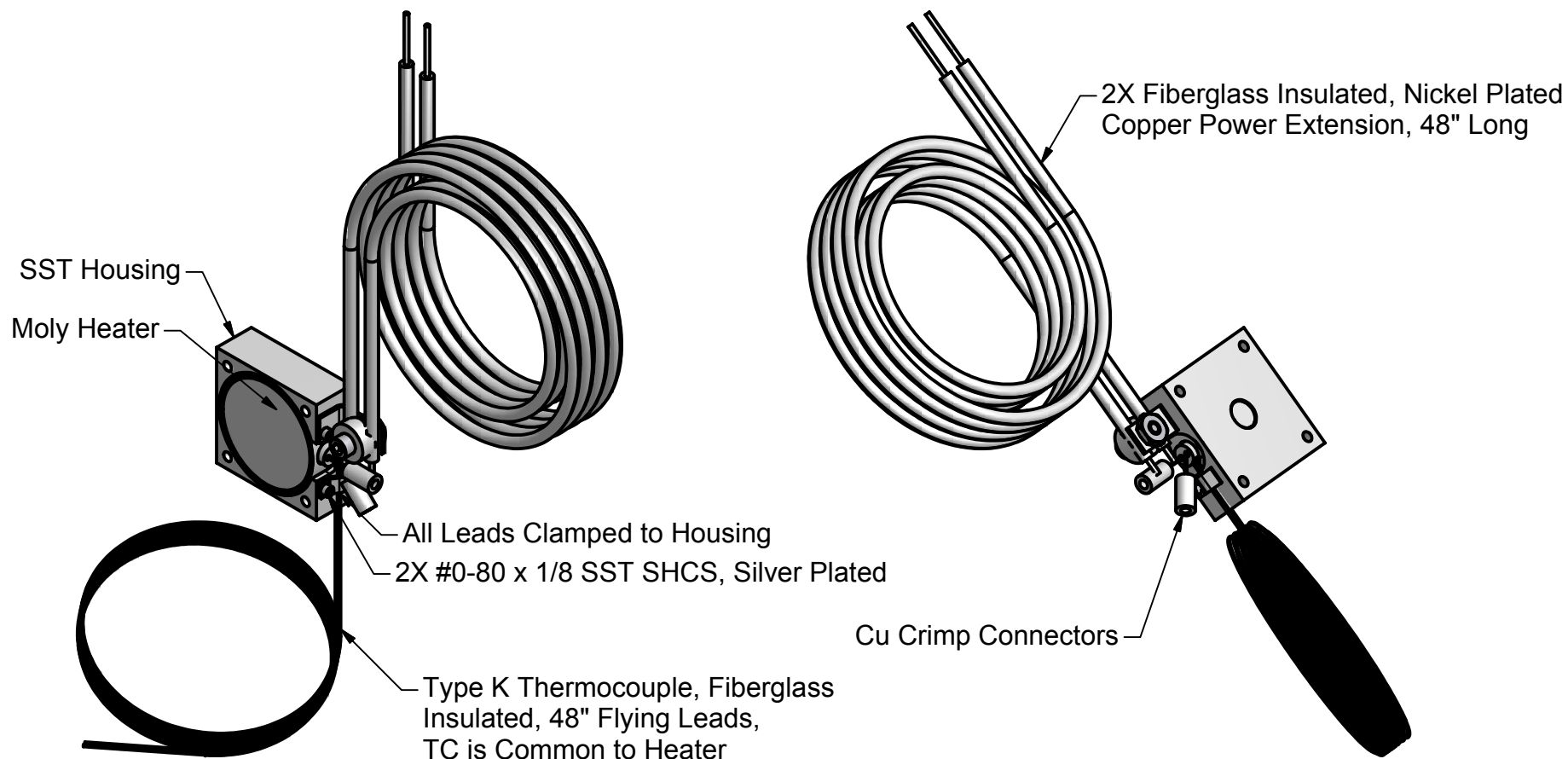

DRAWN mcurtis	11/25/2009
CHECKED	
QA	
MFG	
APPROVED	
Material:	
-	

**HeatWave Labs, Inc.**  
 195 Aviation Way, Suite 100 P: 831-722-9081  
 Watsonville, CA 95076 F: 831-722-5491  
 www.cathode.com

Ø1.0, 500°C UHV Heater Assembly

SIZE A	Cage Code: 1YAN4	DWG NO 105750	REV A
SCALE 3/4	SHEET 1 OF 2		

This document is the property of HeatWave Labs. Its contents may not be reproduced without express written permission of HeatWave Labs.

B

B

A

A

2

1

2

1

2



1

105750

PARTS LIST

ITEM	QTY	PART NUMBER	DESCRIPTION
1	1	105875	Ø1.0, 500°C UHV Heater Assembly, BOM

B

B

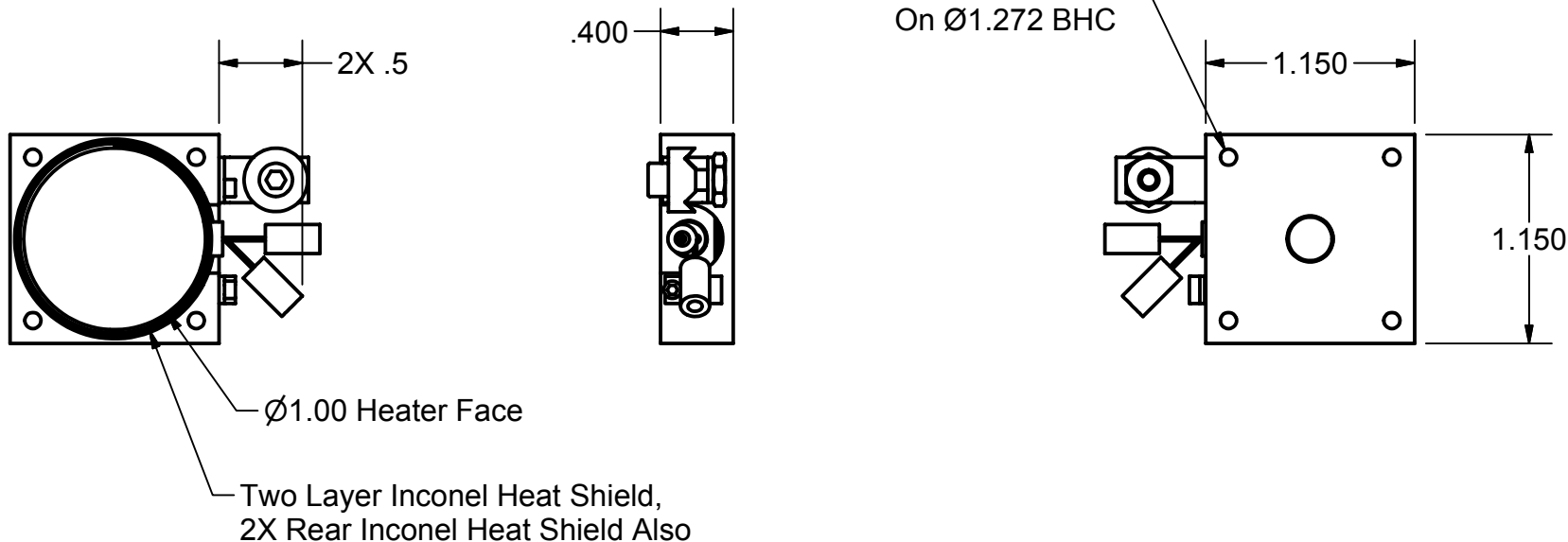

These Views Shown Without Wiring or Thermocouple

A

A

DRAWN mcurtis	11/25/2009
CHECKED	
QA	
MFG	
APPROVED	

<i>HeatWave Labs, Inc.</i>		195 Aviation Way, Suite 100 P: 831-722-9081 Watsonville, CA 95076 F: 831-722-5491 www.cathode.com	
Ø1.0, 500°C UHV Heater Assembly			
SIZE A	DWG NO 105750	REV A	
SCALE 1x	SHEET 2 OF 2		

2



1