

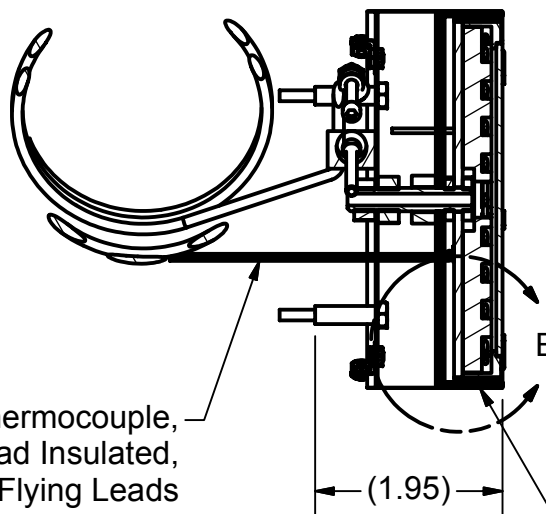

PARTS LIST

| ITEM | QTY | PART NUMBER | DESCRIPTION |
|------|-----|-------------|---|
| 1 | 1 | 105758 | 3.0 Dia., 1200 ° UHV Heater Assembly, BOM |

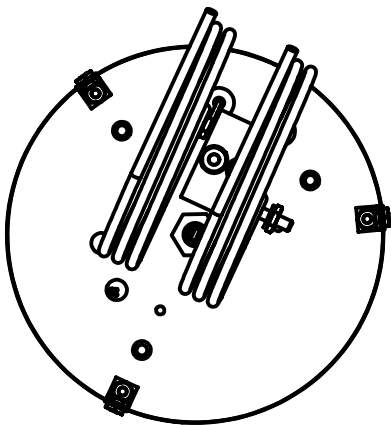

Type C Thermocouple,
Alumina Bead Insulated,
12" Flying Leads

SECTION A-A
SCALE 1 / 2

Ø3.250 PBN Disk

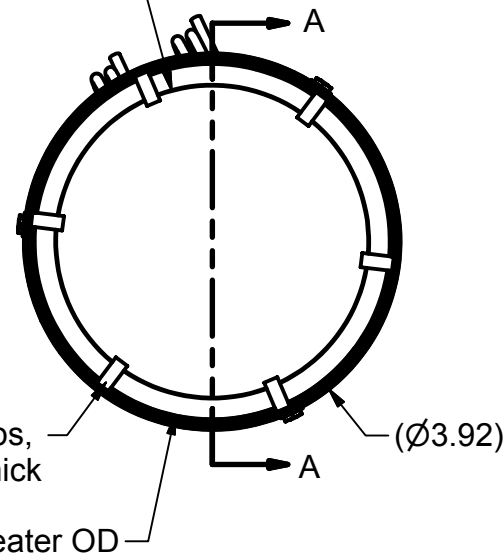

Ta Tabs,
.020 Thick

Ø3.70 Heater OD

Customer Supplied Outer Housing,
Rear Flange & Standoffs

Notes:

- Estimated operation:
9.7V, 21.4A @ 800°C
18.1V, 30.9A @ 1000°C
21.9V, 40.7A @ 1200°C

| | |
|------------------|-----------|
| DRAWN mcurtis | 10/2/2009 |
| CHECKED | |
| QA | |
| MFG | |
| APPROVED | |
| Material: | |

| | | | |
|----------------------------|---------------------|---|-----|
| <i>HeatWave Labs, Inc.</i> | | 195 Aviation Way, Suite 100 P: 831-722-9081 Watsonville, CA 95076 F: 831-722-5491 www.cathode.com | |
| | | 3.0 Dia., 1200°C UHV Heater Assembly | |
| SIZE A | Cage Code: 1YAN4 | DWG NO 105638 | REV |
| SCALE 1/2 | SHEET 1 OF 2 | | |

This document is the property of HeatWave Labs.
Its contents may not be reproduced without
express written permission of HeatWave Labs.





Nut to Secure Screw to Block, Minimal Pressure

Double Nut to Secure Wire Connections

C'Bore to House Screw Head

Terminal Block Assembly
Scale: 1x

2X 10 Gauge x 18" Long Stranded Cu Wire,
Insulated with 101471-08, Fish Spine Beads,
Also Supply 6" ASB-250156 with Shipment
For Customer use if needed

Macor Terminal Block,
Supplies Strain Relief,
Bolted to Ta Housing

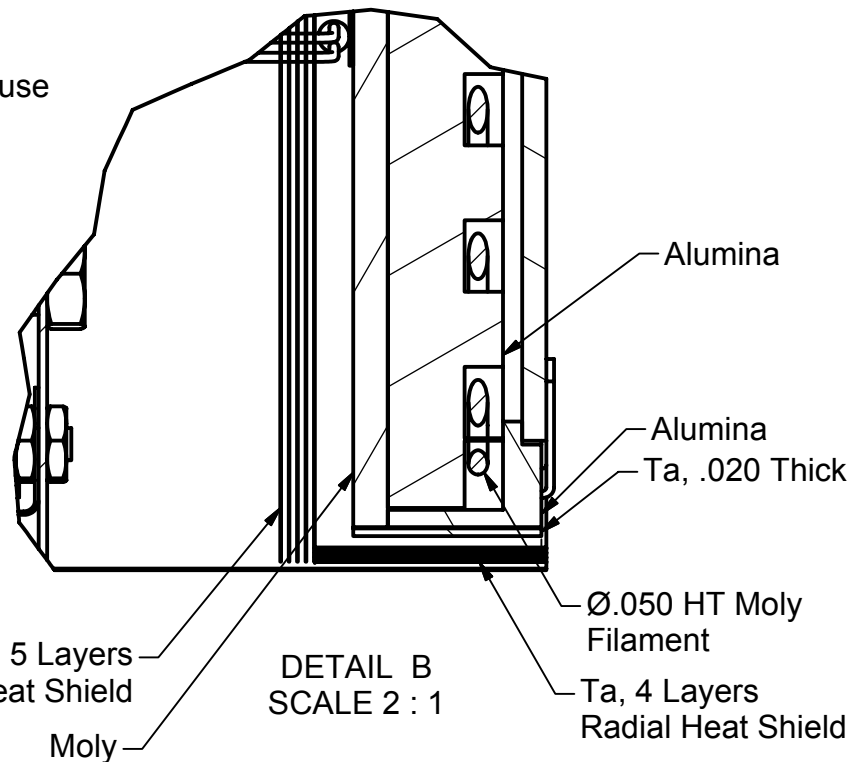

| | |
|------------------|-----------|
| DRAWN mcurtis | 10/2/2009 |
| CHECKED | |
| QA | |
| MFG | |
| APPROVED | |
| | |

| | | | |
|----------------------------|------------------|---|--|
| <i>HeatWave Labs, Inc.</i> | | 195 Aviation Way, Suite 100 P: 831-722-9081 Watsonville, CA 95076 F: 831-722-5491 www.cathode.com | |
| | | 3.0 Dia., 1200°C UHV Heater Assembly | |
| SIZE A | DWG NO 105638 | REV | |
| SCALE 1/2 | SHEET 2 OF 2 | | |

