

PARTS LIST

REVISION HISTORY

ITEM	QTY	PART NUMBER	DESCRIPTION
1	1	105523	Ø1.800 Heater Assembly, BOM

REV	DESCRIPTION	DATE	APPROVED
A	Moved TC back.	11/10/2009	

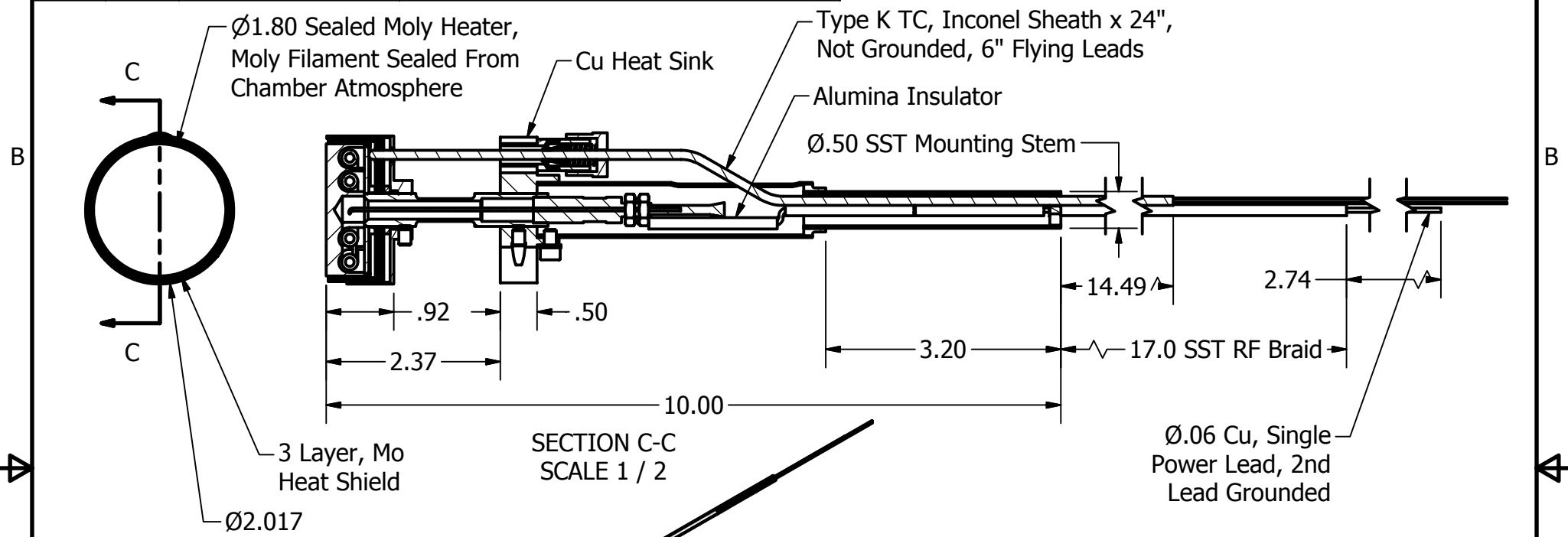

- Notes:
1. Materials used include Moly, SST, Inconel, Alumina and Copper.
 2. Braze materials are Palladium and Au/Cu.
 3. Estimated operation:
13.0V, 17.3A @ 1000°C
22.2V, 23.1A @ 1200°C

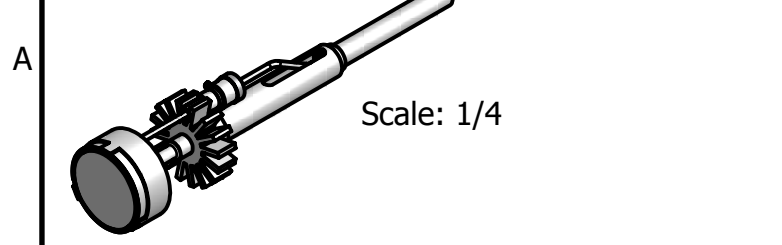

DRAWN mcurtis	6/8/2009
CHECKED	
QA	
MFG	
APPROVED	
Material:	

HeatWave Labs, Inc.
 195 Aviation Way, Suite 100 P: 831-722-9081
 Watsonville, CA 95076 F: 831-722-5491
 www.cathode.com

Ø1.80 Sealed Moly Heater Assembly

SIZE A	Cage Code: 1YAN4	DWG NO 105354	REV A
SCALE 1/2	SHEET 1 OF 1		

This document is the property of HeatWave Labs. Its contents may not be reproduced without express written permission of HeatWave Labs.