

2



1

105305

PARTS LIST

ITEM	QTY	PART NUMBER	DESCRIPTION
1	1	105367	Ø1.0 Sealed Heater Assembly, BOM

2 3/4 CFF, Non-Rotatable, Not Tapped

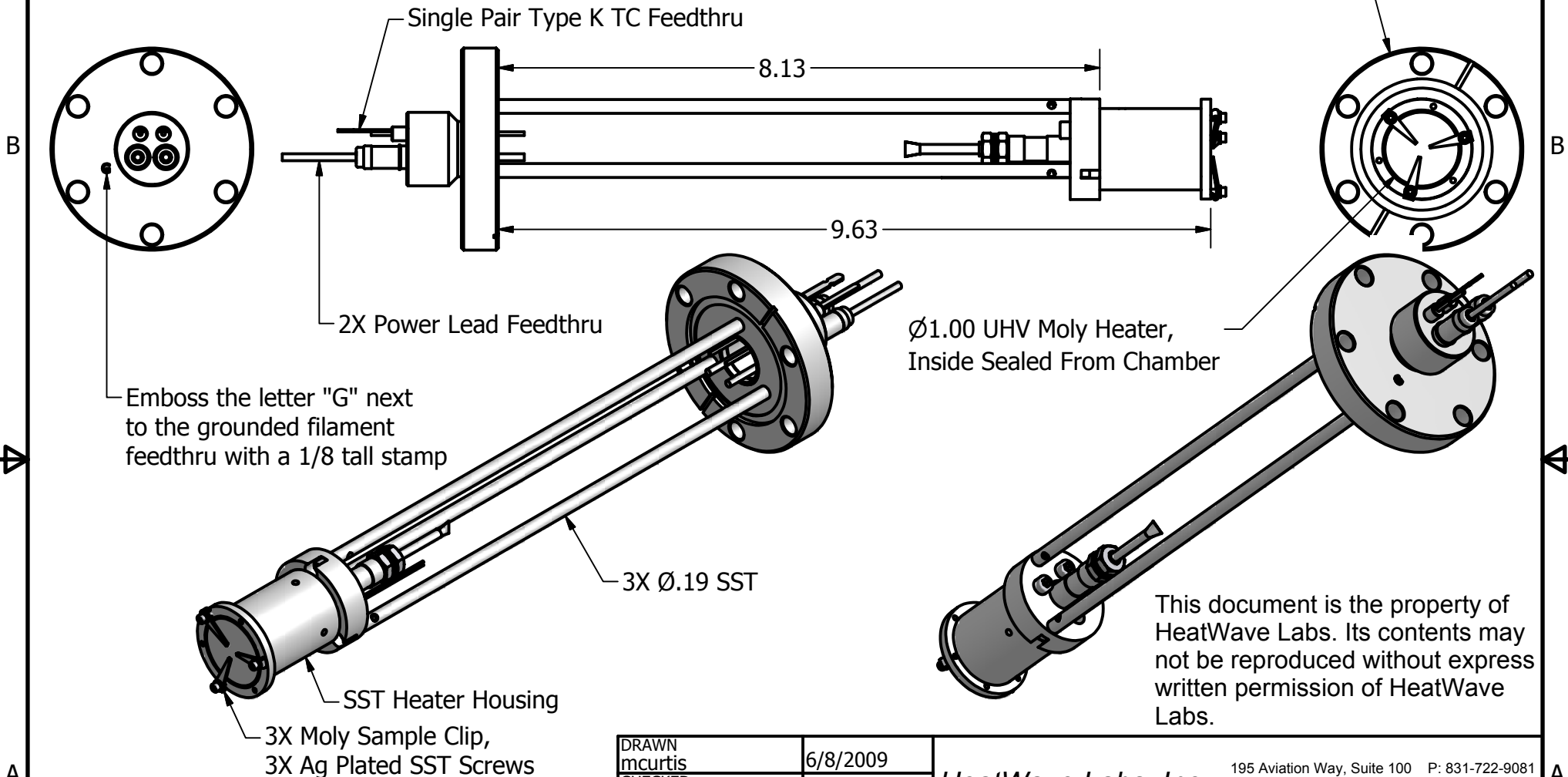

Notes:

1. Filament has one grounded lead, electrically common to flange.
2. Materials of heater are: front and side, Moly, Palco braze: rear, Moly, SST, Ni, Alumina, Palco braze, Cu/Au braze, Chromel, Alumel.
3. Hook up wires between heater assembly and flange are not shown.

DRAWN	mcurtis	6/8/2009
CHECKED		
QA		
MFG		
APPROVED		
Material:		
	-	

HeatWave Labs, Inc.
 195 Aviation Way, Suite 100 P: 831-722-9081
 Watsonville, CA 95076 F: 831-722-5491
 www.cathode.com

 Ø1.0 Sealed UHV Heater w/Sample Clips,
 2 3/4 CFF Mounted w/TC and Power Fedthrus

SIZE	Cage Code:	DWG NO	REV
A	1YAN4	105305	
SCALE	1/2		SHEET 1 OF 1

2



1