

Dash #	Next Assembly
-	-

REV	DESCRIPTION	DATE	APPROVED

REVISIONS

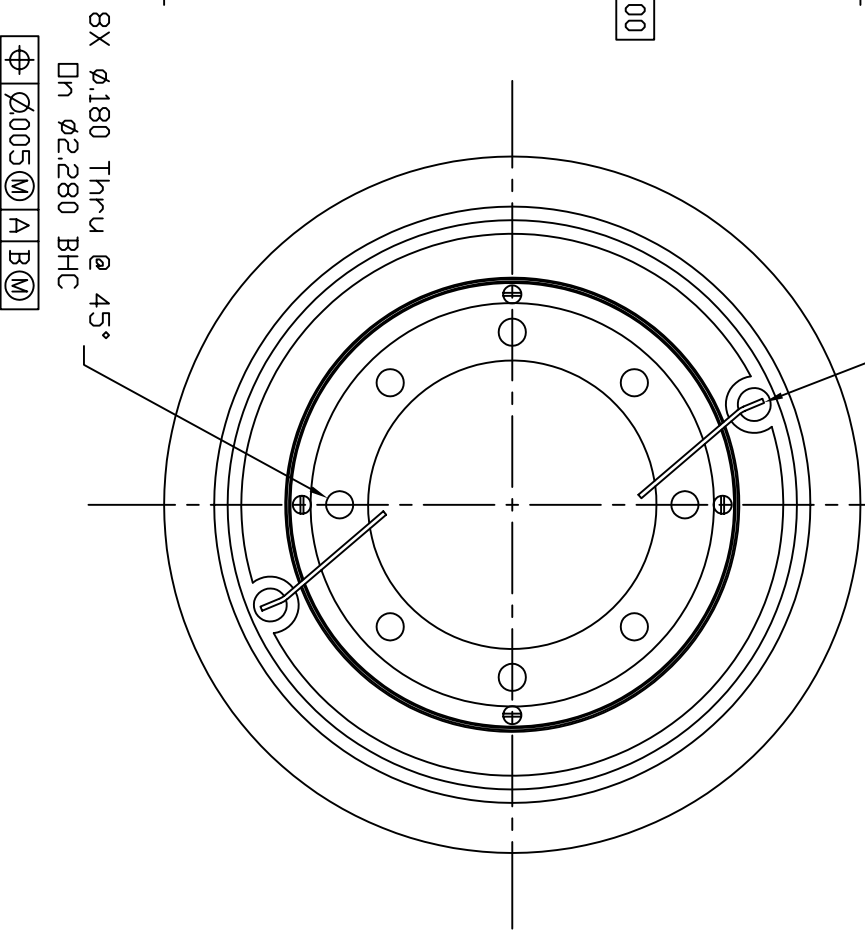
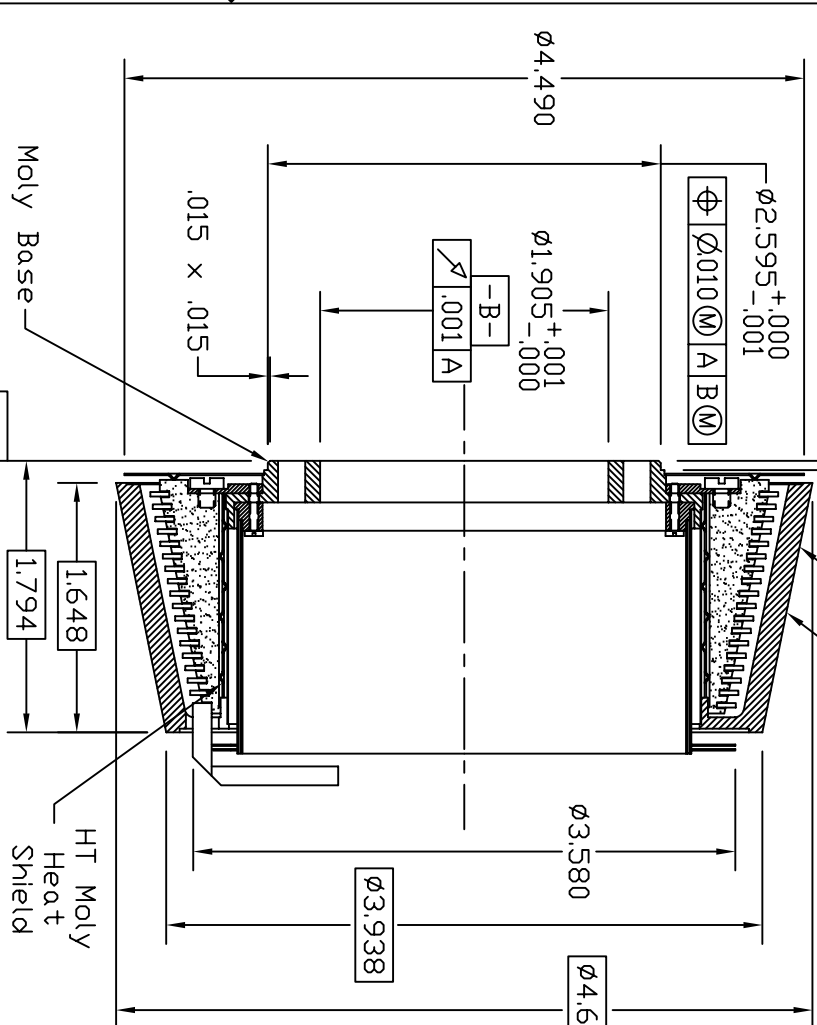

- Notes:
- Estimated operation: 36.5V, 38A @ 1050°C
 - Heat shields are .005 thick HT Moly.

This document is the property of HeatWave Labs. Its contents may not be reproduced or distributed without express written permission of HeatWave Labs.

UNLESS OTHERWISE SPECIFIED ALL DIMENSIONS ARE IN INCHES.
 TOLERANCES ARE:
 XXXX = ±.005 XX = ±.020
 FINISH 63 MICRONS
 ANGLES 0 DEGREE ±30 MINUTES
 EDGES AND CORNERS .005 R MAX

MATERIAL	-
DD NOT SCALE DRAWING	-

Qty.	Part #	Description	Item #
1	104282	ABK Cathode Assembly	1

HeatWave Labs, Inc.

195 Aviation Way, Suite 100 (831) 722-9081
 Watsonville, Ca. 95076 Fax: (831) 722-5491
 Website: www.cathode.com

ABK Cathode Assembly

BY	DATE	SIZE	Cage Code	DWG. NO.	REV
ENGR	M.Curtis	6/8/07	A	104262	-
THIRD ANGLE PROJECTION		SCALE: 0.8X	SHEET: 1/1		