

Dash # Next Assembly

- -

REVISIONS		
REV	DESCRIPTION	DATE

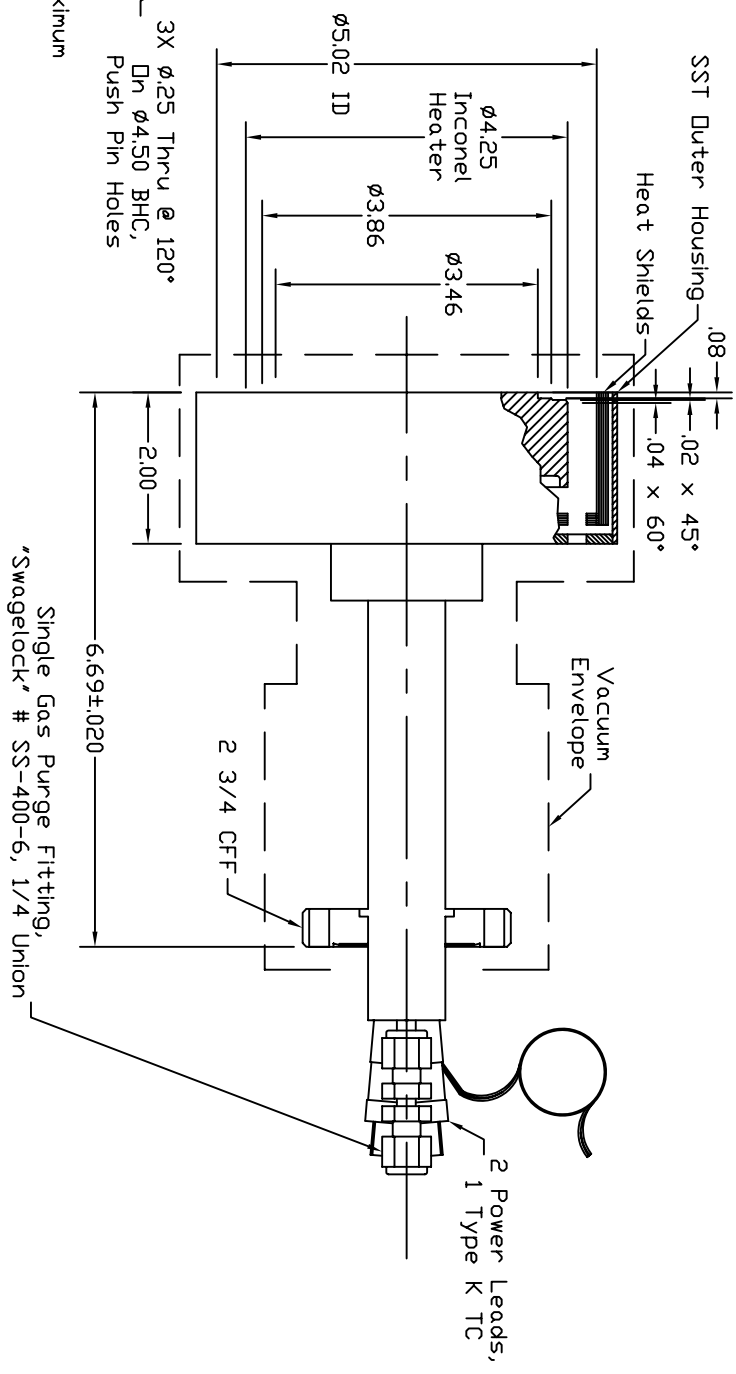
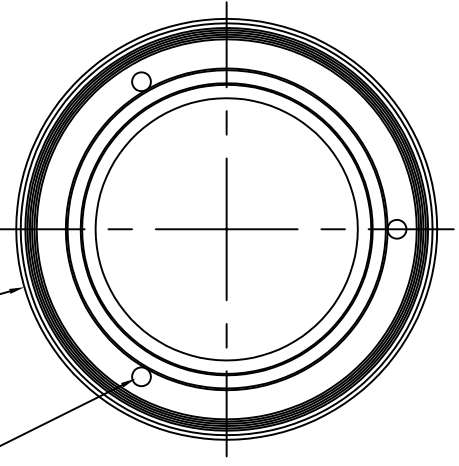

Notes:

- 1.

This document is the property of HeatWave Labs. Its contents may not be reproduced or distributed without express written permission of HeatWave Labs.

UNLESS OTHERWISE SPECIFIED  
ALL DIMENSIONS ARE IN INCHES.  
TOLERANCES ARE:  
XXXX = ±.005 XX = ±.020  
FINISH 63 MICRONDICHES  
ANGLES 0 DEGREE ±30 MINUTES  
EDGES AND CORNERS .005 R MAX

MATERIAL  
-  
DD NOT SCALE DRAWING

Qty.	Part #	Description	Item #
1	103911	Ø4.0 D2 Heater	1

**HeatWave Labs, Inc.**  
195 Aviation Way, Suite 100 (831) 722-9081  
Watsonville, Ca. 95076 Fax: (831) 722-5491  
Website: www.athode.com

BY DATE  
ENGR M.Curtis 12/18/06  
DRAWN

SIZE Code Code DWG. NO. REV  
A 1VAN4 103891 1

Ø4.0 D2 Heater  
SCALE: 0.4X SHEET: 1/1