

Dash #	Next Assembly
-	-

REVISIONS			
REV	DESCRIPTION	DATE	APPROVED

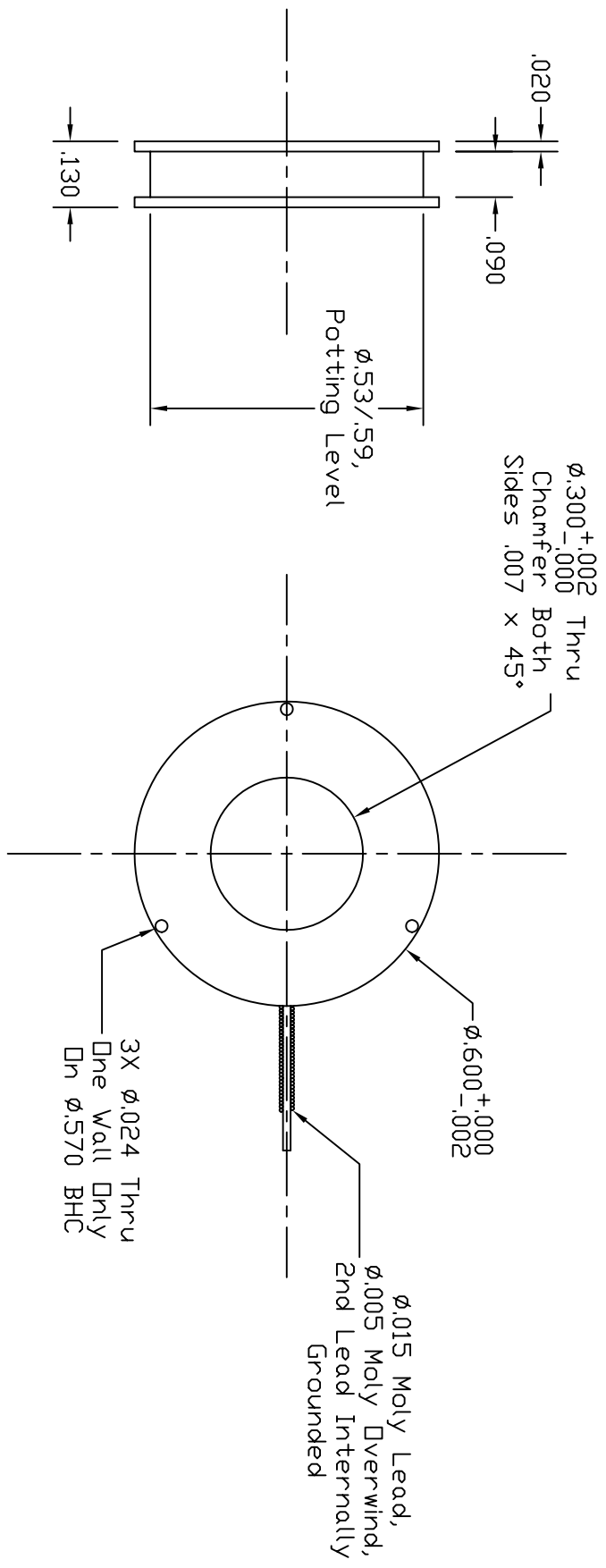

- Notes:
- Estimated Operation:
 2.7V, 2.75A @ 900°C
 3.7V, 3.39A @ 1000°C
 4.8V, 3.75A @ 1100°C
 5.7V, 4.07A @ 1200°C

This document is the property of HeatWave Labs. Its contents may not be reproduced or distributed without express written permission of HeatWave Labs.

UNLESS OTHERWISE SPECIFIED
 ALL DIMENSIONS ARE IN INCHES.
 TOLERANCES ARE:
 .XXX = ±.005 .XX = ±.020
 .XXXX = ±.0005
 FINISH 63 MICRONS
 ANGLES 0 DEGREE ±30 MINUTES
 EDGES AND CORNERS .005 R MAX

MATERIAL
 -

DD NOT SCALE DRAWING

1	102768	$\phi.60$ UHV Heater	1
Qty.	Part #	Description	Item #
HeatWave Labs, Inc. 195 Aviation Way, Suite 100 (831) 722-9081 Watsonville, Ca. 95076 Fax: (831) 722-5491 Website: www.cathode.com			
DRAWN		BY	
ENGR	M.Curtis	DATE	9/28/04
SIZE		DWG. NO.	REV
A	Cage Code 1VAN4	102767	-
THIRD ANGLE PROJECTION		SCALE: 3X	SHEET: 1/1