

Dash #	Next Assembly
-	-

REVISIONS			
REV	DESCRIPTION	DATE	APPROVED
A	Added notes and dash numbers.	11/12/03	MC
A1	Added -04 and "T" to table a.	8/13/07	MC
B	Changed feedthrus to have threads for air side hook up.	8/26/10	MC

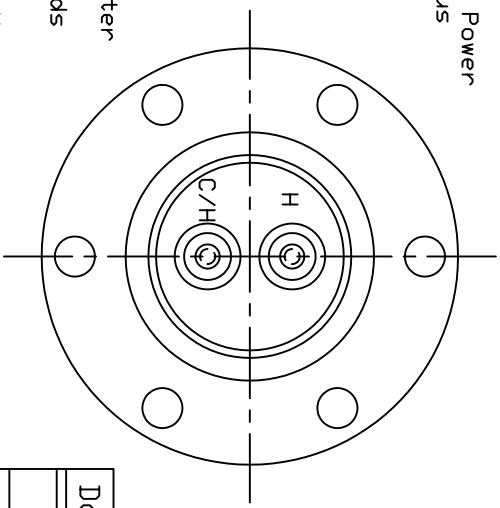
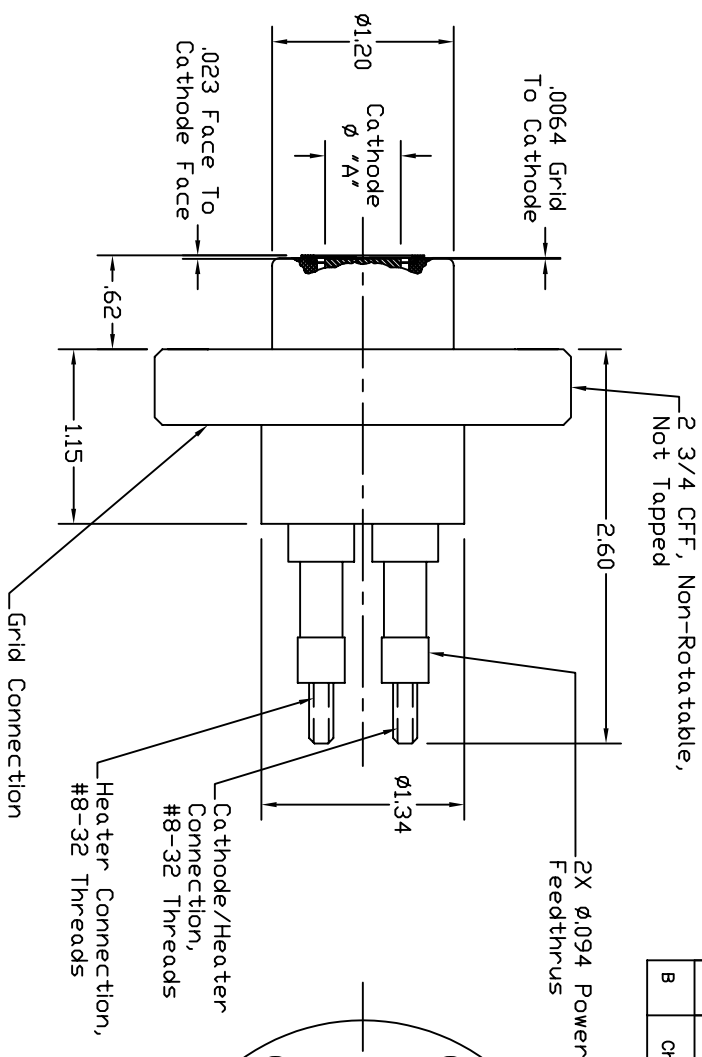

Table A

Dash #	"A"	"T"
-01	Ø.500	90%
-02	Ø.134	90%
-03	Ø.250	90%
-04	Ø.400	75%

- Notes:
1. Gun is shipped under vacuum.
  2. For grid transparency refer to "T" in Table A.

This document is the property of HeatWave Labs. Its contents may not be reproduced or distributed without express written permission of HeatWave Labs.

-04	-03	-02	-01
1	-	-	-
-	1	-	-
-	-	1	-
-	-	-	1

UNLESS OTHERWISE SPECIFIED ALL DIMENSIONS ARE IN INCHES.  
 TOLERANCES ARE:  
 .XXX = ±.005    .XX = ±.020  
 .XXXX = ±.0005  
 FINISH 63 MICRONS  
 ANGLES 0 DEGREE ±30 MINUTES  
 EDGES AND CORNERS .005 R MAX

MATERIAL

DD NOT SCALE DRAWING

**HeatWave Labs, Inc.**

195 Aviation Way, Suite 100 (831) 722-9081  
 Watsonville, Ca. 95076 Fax: (831) 722-5491  
 Website: www.cathode.com

BY	DATE
M.Curtis	10/2/03

2 3/4 CFF Mounted,  
 Gridded Electron Gun

SIZE	Cage Code	DWG. NO.	REV
A	1YAN4	102353	B
SCALE: 08X			SHEET: 1/1