

HeatWave Labs, Inc. 

**HeatWave Labs
Model 101303-23
Temperature Controller**
S/N BG10189



User's Manual

Important Safety Notice



Warning: This instrument operates from and delivers potentially lethal voltages. Observe all precautions when using this device, and particularly be sure that all devices connected to the instrument are safely wired and properly grounded. Always disconnect power to the instrument before opening the enclosure or making any wiring changes.



Caution: Additionally, this device is intended to control heaters and thermal systems, which may be hot and/or dangerous. Beware that damage to heaters and other equipment, possibly resulting in personal injury or death may result from improper use or control of thermal systems. Understand the safety implications of your system and take proper precautions to avoid damage to property or injury to personnel.

Where to Get More Information

This owner's manual represents the most current information at the time it was published; for the latest information, please visit our website: www.cathode.com.

We may also be reached in the following ways:

HeatWave Labs, Inc.
195 Aviation Way, Suite 100
Watsonville, CA 95076-2069

Tel: 831-722-9081
Fax: 831-722-5491
Email: techsales@cathode.com

Warranty and Repair Information

Our products are warranted against defects in materials or workmanship according to our [Standard Product Warranty, TB-166](#).

Model 101303-23 Specifications

- Ramp and soak programmability with storage for 2 profiles, with up to 8 steps per profile
- Autotuning PID control; also supports manual tuning and other control modes, including alarm mode
- Solid-state control utilizing an oversized solid-state relay for long-life and precise control
- Phase-angle fired SCR for use with tungsten heating elements
- Inductively coupled load for use with 8, 16 or 32 volt loads. See Factory Configuration in Appendix A.
- Over-temperature protection utilizing a separately controlled alarm setpoint and an independent mechanical relay in series with the solid state control relay
- Internal SCR is short-circuit protected by a back-panel accessible semiconductor fuse (HWL p/n 101960-01, FWH-020A6F)
- Over-current protection using a front panel circuit breaker
- Open loop protection, shutting down output if open loop operation is detected (factory preset with open loop off)
- Dual LED displays on control module for simultaneous indication of process temperature and setpoint in Fahrenheit or Celsius (default)
- Input power: 100-130 VAC, or 230/240 VAC, 50/60 Hz. See Factory Configuration in Appendix A
- Output power:
 - See Factory Configuration in Appendix A
- Display resolution: 1°
- Absolute accuracy: $\pm 1^\circ$
- Heater connector: 3-pin screw terminal, including ground conductor
- Type K thermocouple sensor input
 - range: 0 to 1370°C
 - ambient rejection: $< 0.1^\circ\text{C}/^\circ\text{C}$
 - connector: standard Type-K
- Enclosure: standard EIA 19" EIA rackmount, 7.0" tall (5 rack units), 14" deep, 44 lbs.
- Ambient temperature range: 0 to 60°C, non-condensing

Table of Contents

Important Safety Notice	ii
Where to Get More Information.....	ii
Warranty and Repair Information	ii
Model 101303-23 Specifications	iii
Overview	2
Control Module Displays and Menu Navigation	3
Limit Module Displays and Menu Navigation.....	4
Getting Started	5
Programming and Executing Profiles	9
Programming a Profile.....	9
Running a Profile.....	11
Resuming a Halted Profile.....	11
Using the Wait-for Process Deviation Function	11
Advanced Features and Settings	12
Setting the autotune point to a lower value.....	12
Switching between Celsius and Fahrenheit	12
Changing the resolution (decimal point).....	12
Power limiting	13
Other features.....	14
Error Messages and Troubleshooting.....	15
Error messages.....	15
Troubleshooting.....	15
Appendix A: Default Factory Configuration.....	17
Input voltage settings	19
Output voltage settings	19
8V output with 120V input.....	20
Appendix B: Model 101303-23 Electrical Schematic.....	21

Overview

The HeatWave Labs Model 101303-23 is a full featured, high quality rackmount temperature controller designed for low-voltage tungsten heater control applications requiring precise, reliable control and ramp/soak programmability.

Over-temperature protection is provided by a completely independent limit controller and sensor. The alarm will disable power to the heater if the alarm setpoint is exceeded. Alarm switching is provided by an independent, internal mechanical relay in series with the solid-state control relay. This alarm scheme provides protection against system runaway if the solid-state relay should fail in the closed position. In addition to over-temperature protection, the Model 101303-23 provides other mechanisms like open loop and open sensor detection to assist in system protection. The phase-angle fired SCR is protected by a semiconductor fuse that can be replaced via back-panel access.

Control Module Displays and Menu Navigation

The Watlow® Series 96 Controller with the ramping software option allows programming of 2 temperature vs. time profiles (called “files”) that can each have up to eight distinct steps programmed into them. Upon power-up, the unit starts at the “Home Page” and indicates the process temperature in the upper display and the setpoint (or **OFF**) in the lower display. While not running a profile, the setpoint can be directly adjusted with the up and down arrow keys. The setpoint is registered about 2 seconds after the last pressing of either up or down arrow.

Management, programming, and execution of temperature vs. time profiles are explained in the *Programming and Executing Profiles* section.

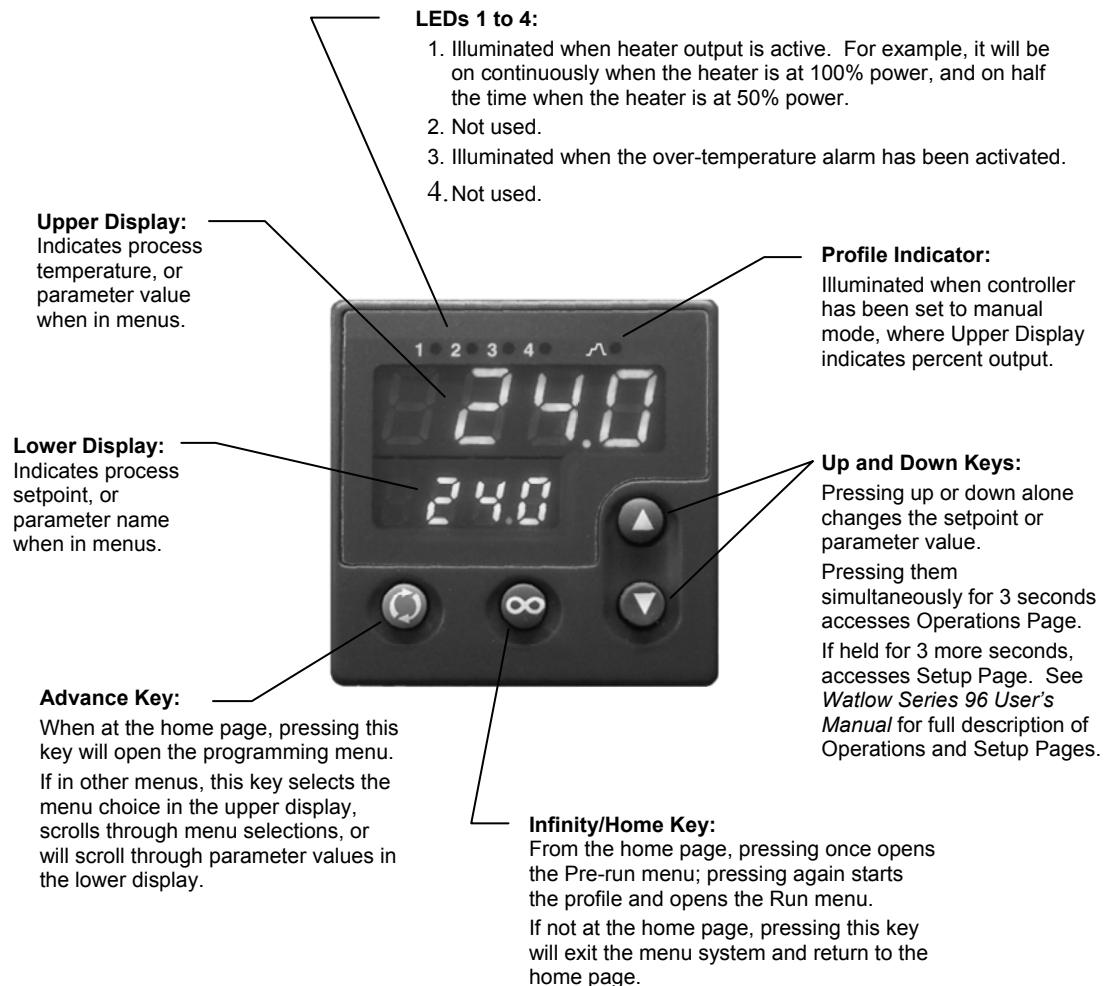

Figure 1 Control module keys and displays

Limit Module Displays and Menu Navigation

The Watlow® Series SD Limit Controller monitors the Limit sensor and will shut down output power if the limit controller’s alarm setpoint is exceeded. Upon power-up the limit sensor’s process temperature is indicated in the upper display. The alarm setpoint is set by pressing the blue Advance key until “Al.hi” is displayed in the lower (right) display. The value of the alarm setpoint should be visible in the upper (left) display. Use the up and down arrows to adjust the alarm setpoint value. The setpoint is registered about 2 seconds after the last pressing of either up or down arrow. The limit has been factory preset. See Appendix A for factory configuration.

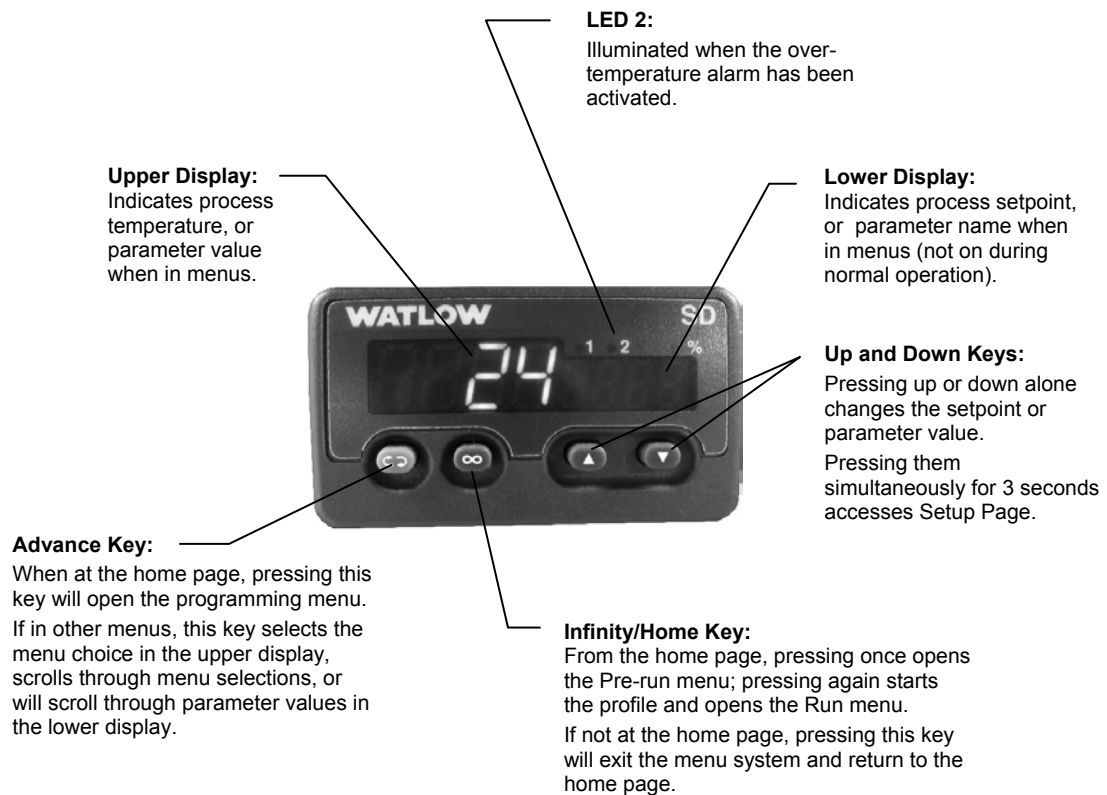

Figure 2 Limit module keys and displays

Watlow is a registered trademark of Watlow Electric Manufacturing Co.

Getting Started

Getting started using your new HeatWave Labs Temperature Controller should be quick and easy. The *Error Messages and Troubleshooting* section of this manual describes errors that may be encountered during this process. For more details about the operation of the control module, consult the attached *Watlow®* Series 96 user's manual.

This manual is also available for download at the HeatWave labs web site, www.cathode.com or at <http://www.cathode.com/pdf/series96man.pdf>.

To ensure the quickest and most reliable startup, please follow the eight steps below in the order shown.

1. *Unpack the instrument*

Be sure that you received the following items in good condition. If there was any damage in shipping, please keep your shipping containers and contact the factory immediately.

- Model 101303-23 instrument chassis
- Power Cord
- HeatWave Labs p/n 101960-01 (FWH-020A6F) 20A, Fast Acting Semiconductor Fuse (Installed)
- Manuals: HeatWave Labs Model 101303-23, *Watlow®* Series 96, and *Watlow®* Series SD user's manuals
- HeatWave Labs Catalog

2. *Connect the instrument*



Warning: This instrument is designed for use with input voltage, current and frequency as specified in the Factory Configuration in Appendix A only; serious equipment damage and/or injury will occur if it is connected to improper power.



Caution: Air vents are located on top, bottom and rear of the instrument. Airflow must not be restricted at these locations.

1. Make sure the switch on the front panel is in the off position.
2. Plug your process thermocouple, Type K, into the control sensor receptacle on the rear panel. (If you need to add connectors to your sensors, do it now. Remember thermocouples are polarity sensitive, for Type-K the yellow wire is positive.)



Warning: This unit is designed to deliver maximum output voltage and amperage to the load at 100% controller output. If the load is designed to run at lower than the maximum output capability, the controller must be adjusted to limit the voltage to this load. The factory has limited the output of this controller as per the controller settings listed in the Factory Configuration in Appendix A.

It is likely that the user will need to change these settings to reach desired operating temperatures and ramping rates. Consult the Series 96 Manual for necessary settings.



3. Plug the unit into a power receptacle.
4. **Do not** connect the system heater at this time.



Warning: This instrument is designed for use with input voltage, current and frequency as specified in the Factory Configuration in Appendix A only; serious equipment damage and/or injury will occur if it is connected to improper power.

3. Power up the instrument

1. Turn the instrument on using the front panel switch.
2. After a few seconds the sensor temperature will be visible in the upper display of the control module (in Celsius) and the setpoint will be visible in the lower display. Verify that this sensor temperature appears reasonable.

4. Set over-temperature alarm set point

The over-temperature alarm setpoint of the limit module must be set. For more information about the user interface, see *Limit Module Displays and Menu Navigation* above.

Note: The module will exit the menu system and return to the main display in 60 seconds if no keys are pressed.

If the limit sensor reaches this setpoint for any reason the heater output will be shut off until the user resets the instrument manually (by pressing the infinity key on the limit module after the temperature has dropped more than 2 °C below this alarm limit). **On the LIMIT module:**

1. Press Advance key until “A1hi” is displayed in the lower (right) display.
2. The alarm setpoint may now be set with the arrow keys.
3. Return to the main display by pressing the infinity key.

5. Set the setpoint

1. The setpoint can be adjusted using the up and down arrow keys from the home page (not while inside any other menus). At this point, adjust the setpoint to a value below the current process temperature to avoid applying power to the output. The lower display shows **OFF** if the setpoint is adjusted to its lowest permissible value (0° C).

6. Verify proper system performance

1. If your system will be damaged by 100% output power, set the power limits on the control module as described in the Advanced Features section. In Appendix A, the Power Limit Parameters factory preset is shown.
2. Turn the unit off, plug in the heater, and turn the unit back on again.
3. Set the setpoint a few degrees above the present process temperature so that output power will be applied.
Verify that:
 - a. LED #1 illuminates or begins to flash intermittently, indicating heater output is activated, and
 - b. The temperature begins to rise.
4. If the system temperature does not begin rising, shut off power and investigate sensor and heater connections and integrity. If the circuit breaker trips, or any errors are displayed, refer to the *Error Messages and Troubleshooting* section of this manual.

7. Autotune the system

Excellent thermal control is normally attained by automatically tuning the control parameters (described below) to the specific thermal system. The controller should be autotuned the first time it is used and whenever the thermal properties of the system being controlled change significantly.



Warning: For systems that cannot tolerate the overshoot that can occur during the autotuning process, change the ATSP parameter (as described in the advanced features) to a lower value so that the system autotunes around a lower value. The default autotuning point is 90% of the setpoint. This may also be set to 100% to tune the controller at the setpoint if your system allows.

Be aware that the autotuning algorithm turns power on at 100% to measure system response. Operating at 100% duty cycle may damage some types of heaters, especially those used in high temperature furnaces. Do not autotune the system if it will be damaged by 100% output power. If this is the case, refer to the *Watlow*[®] Series 96 manual for the manual tuning procedure.

1. Set the control setpoint to a safe operating value for your system.
2. On the control module, press the two arrows keys simultaneously until **OPER** appears in the lower display.
3. Scroll up or down with the arrow keys until **USER** appears in the upper display.
4. Press the blue advance key once to select this user menu.
5. Press the blue advance key once or until **RUE** is displayed in the lower display of the control module. Use one of the arrow keys to change the upper display from **OFF** to **TUNE**.
6. Press the infinity key to return to the main display and initiate the autotune sequence. The upper display will flash **TUNE** alternately with the temperature until it is done autotuning. This process typically takes from a few minutes for small systems to over an hour for larger systems.

8. Verify safe alarm conditions

Your temperature controller is now configured for your system and ready to use. During normal operation, the current process temperature will be visible in the upper display and the setpoint temperature in the lower display.

If the over-temperature alarm setpoint is exceeded (optional feature), the message **REH** will flash in the upper display of the limit module and heater output will be disabled. This alarm can be cleared by pressing the infinity key after the process temperature has fallen more than 2 °C below the alarm setpoint.

Programming and Executing Profiles

This section outlines how to manage and execute temperature vs. time profiles. Detailed explanation of the menu structure and profile parameters can be found in the *Watlow® Series 96 User's Manual*.

Note: The default settings of the HeatWave Labs Model 101303-23 allow for only a subset of step parameters that are available in the Watlow Series 96 Controller. For example, by default, the “program type” parameter found in the Global Menu is set to “time based”, which means setpoint steps are specified in time durations as opposed to being specified as a ramp rate in degrees per unit time. In addition, event inputs and outputs are not used. Therefore, the event handling functions and “wait for event” features are not implemented.

Three menus are used to manage and execute profiles: the Pre-run Menu, the Run Menu, and the Programming Menu. They can be accessed from the Home Page of the system. The Home Page is essentially the main display, where process temperature and setpoint are displayed, and when the unit is not in another menu.

Menu	Function
Programming	Allows the user to program the steps that are stored in the two profiles. Use the blue Advance key to scroll through parameters and press the Infinity key to exit the menu.
Pre-Run	The Pre-Run menu allows the user to select a file and step number from which to begin execution, or to resume a previously halted profile. Enter the Pre-Run menu by pressing the Infinity key from the Home Page. Scroll through the menu using the blue Advance key. While in the Pre-Run menu, the Profile Indicator will be flashing.
Run	The Run menu is available while a profile is running, allowing the user to view the setpoint and time remaining for the currently running step. Enter the Run menu (and start the selected file and step) by pressing the Infinity key from the Pre-Run menu. Scroll through the menu using the blue Advance key. While in the Run menu, the Profile Indicator will be continuously illuminated.

Programming a Profile

Two separate and distinct profiles, each containing up to eight steps may be stored in the controller. The step type can be any one of four step types available: set point step, soak step, jump loop step, or end step. Various parameters will need to be specified for each step, the number and types of which will depend on the step type chosen.

The general procedure for programming a profile is to

1. Enter the programming menu on the control module by pressing the blue Advance key once from the Home Page while the program is on hold or not running.
2. Select the file number by choosing number 1 or 2 while the **FILE** parameter is shown in the lower display, and pressing the blue Advance key.
3. Select the step number within the selected file while the **STEP** parameter is visible in the lower display, and press the blue Advance key.
4. Select the step type (as described below) for each step in the profile. After specifying a step type, select type-specific parameter values.
5. Repeat above procedure for each step in the profile.

Step Types

The step type can be any one of four step types available: set point step, soak step, jump loop step, or end step. Various parameters will need to be specified for each step, the number and types of which will depend on the step type chosen. The purpose of each step type and the parameters that need to be specified are detailed below.

Step Type	Available Parameters
Set Point Step: SEPE ramp to a setpoint in a specified amount of time	<ul style="list-style-type: none"> ▪ SP Set point value (0 to 1370°C) ▪ Hour Hours (0 to 99) ▪ Min Minutes (0 to 59) ▪ SEC Seconds (0 to 59)
Soak Step: SoRH remain at a setpoint for a specified amount of time	<ul style="list-style-type: none"> ▪ Hour Hours (0 to 99) ▪ Min Minutes (0 to 59) ▪ SEC Seconds (0 to 59) ▪ WdE Wait-for deviation value (if a value is entered, the profile will wait until the process values falls within the range defined by the setpoint \pm this value)
Jump Loop Step: JL allows for jumping and looping to other steps in either of the two profiles	<ul style="list-style-type: none"> ▪ JF Jump File (1 or 2) ▪ JS Jump Step (1 to 8) ▪ JC Jump Count (0 to 255): the number of time the jump is to be executed; a value of zero specifies an infinite loop
End Step: End specifies end of profile and the state of control when the profile is ended	<ul style="list-style-type: none"> ▪ End End state (Hold or OFF): If Hold is selected, the controller will maintain the same setpoint as that specified in the previous step. If OFF is selected, the controller output is set to zero and OFF is shown in the lower display.

Running a Profile

The user can start executing a program at any step within either profile.

To run a profile:

1. Enter the Pre-Run menu on the control module by pressing the Infinity key once from the Home Page (while a profile is not already running). The Profile Indicator will begin flashing.
2. The upper display shows the file number to be run and **FILE** is shown in the bottom display. Use the up and down arrow keys to select which file number to run.
3. Press the blue Advance key to accept the file number and advance to the step selection.
4. Use the arrow keys to select the step number at which to begin running the profile.
5. Press the Infinity key and the profile will begin executing from the specified step, and the Profile Indicator will change from flashing to continuous illumination.
6. You may view the currently running step parameters by pressing the blue Advance key multiple times.
7. To stop the profile, press the Infinity key when the profile is running.

Resuming a Halted Profile

If no changes are made to the profiles after a profile has been halted, the profile can be resumed from the same step from which it was halted.

To resume the halted profile:

1. Press the Infinity key on the control module once to enter Pre-run Menu.
2. Press the blue Advance key twice until **RESU** appears in the lower display. The upper display will show the file and step number at which the profile was halted and will be resumed. Note the **RESU** parameter only appears in the Pre-Run menu if a profile had been previously halted.
3. Press the Infinity key to resume the profile.

Using the Wait-for Process Deviation Function

For each soak step in a profile, a Wait-for Process Deviation value (**WJDE**) can be entered. If a value is entered, the controller will wait until the process value falls within the deviation band defined by that step's setpoint value \pm the Wait-for deviation value. The controller will begin decrementing the time left in that step only after the Wait-for condition has been met, and will continue to do so regardless of the condition or process changes during the remainder of the step.

Advanced Features and Settings

There are numerous advanced features supported on the control module that may be useful in specific circumstances. The most common ones are listed below. Consult the *Watlow® Series 96 User's Manual* for more details on these and other options.

Setting the autotune point to a lower value

1. On the control module, press the two arrows keys simultaneously until **OPER** appears in the lower display
2. Use the arrow keys to scroll until **USER** appears in the upper display.
3. Press the advance key once to select this user menu.
4. Press the advance key three times or until **RESP** appears in the lower display.
5. Use the arrow keys to adjust the value (in the upper display) to the desired percentage of setpoint at which to autotune. For example, if **RESP** is set to 80, and the setpoint is set to 750 degrees, it will autotune at 600 degrees.
6. Press the infinity key to return to the main display.

Switching between Celsius and Fahrenheit

The instrument is shipped with each module configured to display temperature in Celsius. To change to Fahrenheit or back to Celsius:

1. On the control module, press the up and down arrows simultaneously. After three seconds the word **OPER** will be visible in the lower display. Continue pressing both keys until **SEE** appears in the lower display
2. Use the arrow keys to scroll through the parameters until the upper display shows **GLBL**.
3. Press the advance key to select the global menu.
4. Press the advance key twice, until the lower display reads **C-F**. Use the arrow keys to select either **°F** or **°C**.
5. Press the infinity key to return to the main display.

Changing the resolution (decimal point)

The instrument can be configured to display tenths of a degree, but if tenths are displayed, the maximum temperature that can be reached is 1000 degrees.

To change the resolution of the control module:

1. On the control module, press the up and down arrows simultaneously. After three seconds the word **OPER** will be visible in the lower display. Continue pressing both keys until **SEE** appears in the lower display
2. Use the arrow keys to scroll through the parameters until the upper display shows **INP1**.
3. Press the advance key to select the Input 1 menu.

4. Press the advance key five times, until the lower display reads **DEC 1** and the upper display reads 0.0. Use the arrow keys to toggle this to 0.
5. Press the infinity key to return to the main display.

Power limiting

Some heaters, especially those used in furnaces, must be controlled quite carefully. Heaters with a negative temperature coefficient of resistance may be damaged if operated at full power at low temperatures. Metal film radiative heaters may not tolerate large duty cycle at high temperatures. The Model 101303-23 allows for two independent power limits and a temperature breakpoint to be set.



Warning: This unit is designed to deliver maximum output voltage and amperage to the load at 100% controller output. If the load is designed to run at lower than the maximum output capability, the controller must be adjusted to limit the voltage to this load. The factory has limited the output of this controller as per the controller settings listed in the Factory Configuration in Appendix A.

It is likely that the user will need to change these settings to reach desired operating temperatures and ramping rates. Consult the Series 96 Manual for necessary settings.

To enable power limiting in the control module:

1. On the control module, press the up and down arrows simultaneously. After three seconds the word **OPER** will be visible in the lower display. Continue pressing both keys until **SEL** appears in the lower display
2. Use the arrow keys to scroll through the parameters until the upper display shows **GLBL**.
3. Press the advance key to select the global menu.
4. Press the advance key five times, until the lower display reads **PLSP**. Use the arrow keys to adjust the upper display to the desired temperature breakpoint where the controller will switch to the power limits set below.
5. Press the advance key once so that the lower display shows **PL a**. Use the arrow keys to select the power limit, in percent, for temperatures above the temperature breakpoint set in step 4.
6. Press the advance key once so that the lower display shows **PL b**. Use the arrow keys to select the power limit, in percent, for temperatures below the temperature breakpoint set in step 4.
7. Press the infinity key to return to the main display.



Caution: The autotune algorithm overrides these power limits during its execution. Do not autotune your system if it can be damaged by 100% duty cycle.

Other features

There are number of other features which are supported on the controller, but are typically only useful under very special circumstances. These are described briefly here. Please consult the *Watlow*[®] Series 96 user's manual for more information.



Caution: There may be subtle intricacies and implications for system operation when implementing these advanced features. These alternate modes are not recommended except for use by expert users in special applications.

1. **Bumpless Failure Mode:** the controller output may be configured to keep outputting a fixed percent power rather than shutting off after a sensor fault.
2. **Additional alarm configurations:** The over-temperature alarm may be configured to be non-latching (default is latching, meaning it must be manually reset even when the process is back in the safe region). The alarm may be configured to be two-sided, silenceable (ability to be overridden), and/or triggered by a deviation from setpoint. These other alarm modes should be very well understood before being implemented and are not recommended for general use.
3. **Calibration:** Sensor input and analog output may be manually calibrated to change offsets or gains. This is rarely necessary since incorrect offsets and scaling are almost always caused by improper grounds, faulty wiring, or other pathological problems. The controller should not be recalibrated unless it is certain that there are no other problems.
4. **PID parameters:** PID parameters may be manually adjusted. Note that control can rarely be improved upon, and danger of adversely affecting control performance is eminent.

Error Messages and Troubleshooting

Error messages

The control module is capable of displaying a number of errors and alarm conditions. These messages are described below. For more details, consult the *Watlow® Series 96 Manual*.

Message	Meaning and Corrective Action
[A3h] flashing in upper display	Recorded process temperature has exceeded alarm limit (over-temperature setpoint). Check value of alarm limit and integrity of sensor. When the process temperature falls more than 2 °C below the alarm limit, clear the error by pressing the reset key. Alternatively, this alarm may be cleared by cycling power to the instrument once the process temperature has fallen below the alarm limit.
[OPLP] flashing in upper display	Open loop error. The controller has been outputting 100% power but its sensor temperature is not changing. Verify that the sensor is located properly and that the heater is connected and functioning properly. This error is cleared by cycling power to the unit. This error indicates a thermal system malfunction -- do not ignore it!
[AutE] flashing in upper display	System is autotuning (this only occurs when initiated manually by the user). No action is necessary, although autotuning sequence may be terminated by setting [Aut] parameter to [OFF] in main menu.
[Err1] , [Err2] , [Err3] , or [Err4] in upper display	Sensor errors. Verify sensor connections and continuity. Unit will continue to display error condition until power is cycled or error is cleared by pressing the infinity key
[Er 4] through [Er 16] in upper display	Internal module errors, not normally seen. Cycle power to unit, and if problem persists call factory.

Troubleshooting

Below are some tips to resolve problems not identified by the standard error messages:

Symptom	Possible causes
Displayed temperature goes down when heaters turn on.	Thermocouple leads reversed. Shut off power immediately and check wiring of sensor.
Circuit Breaker trips	Check that heater is sized properly. The Model 101303-23 will not deliver more than 15 Amps. Check that the heater power is not shorted to ground anywhere in the system.

Symptom	Possible causes
Heater never heats; open loop errors cannot be avoided.	Check that heater is sized properly. If so, internal transformer may have failed. Call factory.
Over-temperature alarm will not clear.	This alarm limit has a two-degree hysteresis. The process temperature must fall more than 2 °C below the alarm set point before it can be cleared with the reset key. This hysteresis may be overridden by cycling power to the instrument once the process temperature has fallen below the alarm limit.
Temperature fluctuates by more than 1 degree.	Verify the unit has been autotuned in the current thermal configuration and near the setpoint temperature. If not do so.
Unit does not control. It heats regardless of setpoint, until alarm limit trips.	The solid-state relay may have failed. This is unlikely unless the output has been shorted and the semiconductor fuse did not properly function (blow). Call factory.
Control module does not display anything, or displays but is not functioning properly.	Check that circuit breaker is on, and line voltage is present. If so, disconnect power, remove cover, and ensure all connectors on the back of the control module are securely in place.

Appendix A: Default Factory Configuration

If for any reason the instrument settings become corrupted, the instrument must be reconfigured with the values listed below. Additionally, it will then be necessary to reset the setpoint, alarm limit, autotune the controller, and reset any other advanced configurations that have been changed for your system. Refer to the *Watlow® Series 96 User's Manual* for more information.



Warning: This unit is designed to deliver up to 32 Volts and 47 Amps to the load at 100% controller output. If the load is designed to run at lower than 32 Volts, the controller must be adjusted to limit the Voltage to this load. The factory has limited the output of this controller as follows:

Power Limit Set Point (PLSP)	300°C
Power Limit Above (PL A)	50%
Power Limit Below (PL B)	25%

It is likely that the user will need to change these settings to reach desired operating temperatures and ramping rates. Consult the Series 96 Manual for necessary settings.

Table A1: Power input and output (Load) settings

This unit can be internally configured by the factory for 120VAC or 240VAC and 50 Hz or 60 Hz input. The output can be set to 32V/47A, 16V/94A or 8V/94A. This unit has been configured at the factory as follows:

I/O Setting	Units	Value
Input Voltage	Volts, AC	120
Output Voltage	Volts, AC	32
Output Current	Amps, AC	47, max
Line Frequency	Hertz, Hz	50 or 60

Table A2: Control Module Settings

Menu Location	Parameter	Value
Oper>ALM	A1hi	700
Set>glbl	C_F	C
Set>glbl	Err	Lat
Set>glbl	Fail	Off
Set>glbl	PLSP	300C
Set>glbl	PL A	50%
Set>glbl	PL B	25%
Set>glbl	OPLP	Off
Set>InP1	In 1	H
Set>InP1	Dec1	0.0
Set>Out1	Prc1	4-20
Set>Out3	Ot 3	AI
Set>Out3	Lat3	Yes
Set>Out3	Sid3	Hi

Input voltage settings



Caution: Input and output voltages can be changed with internal transformer tap settings. The information below is for reference only and to be done only by the factory or qualified technician.

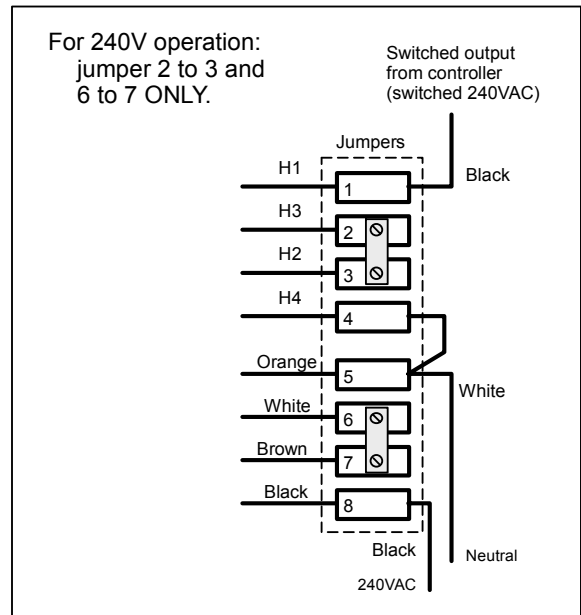
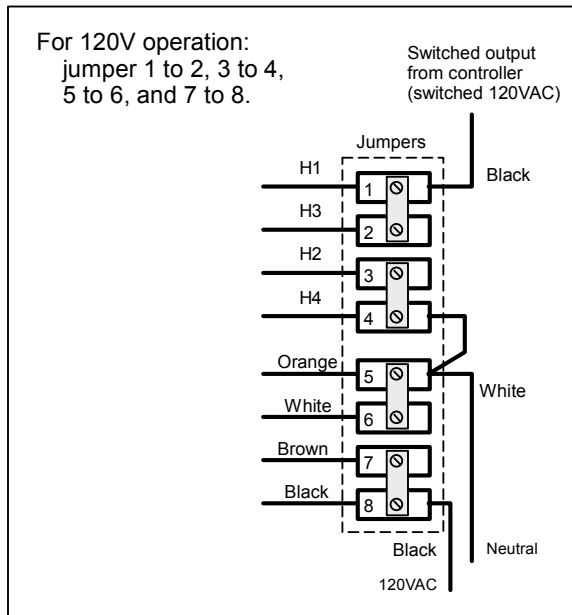

Output voltage settings

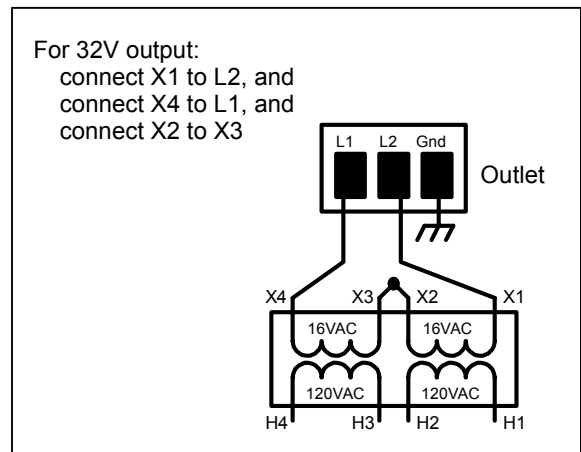
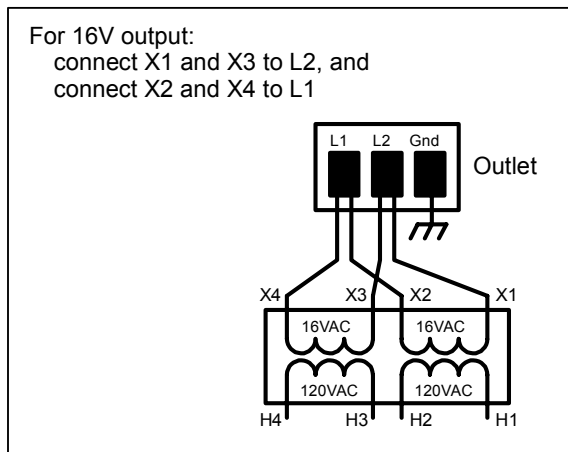

8V output with 120V input

Note: 8V output configuration is only possible at 120V input. Current is limited to 94 Amps when output is configured for 8 Volts output.

For 8V output and 120V input:

connect X1 and X3 to L2, and
connect X2 and X4 to L1

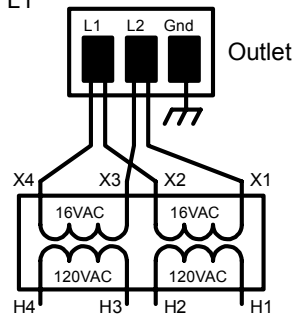

jumper 2 to 3,
5 to 6, and 7 to 8.

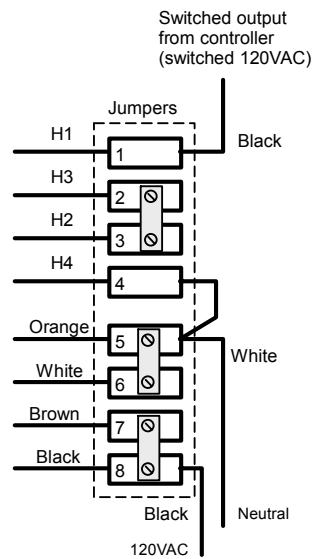

Appendix B: Model 101303-23 Electrical Schematic

