

PARTS LIST

ITEM	QTY	PART NUMBER	DESCRIPTION
1	1	106940	6 CFF Mounted 101491-01, BOM

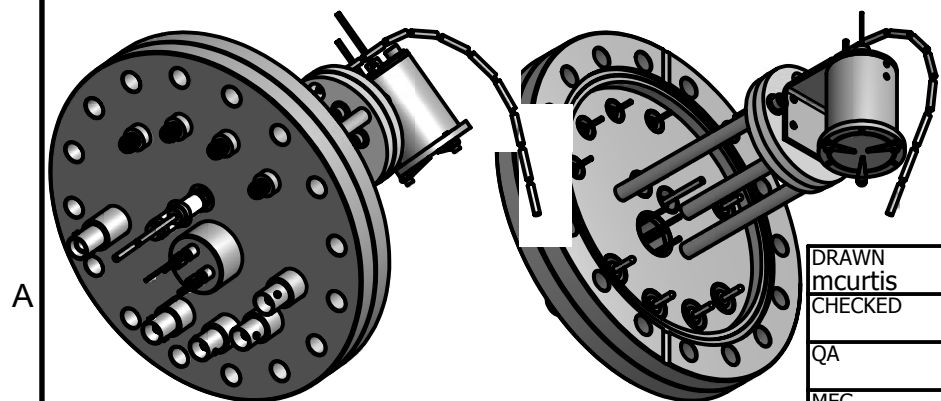
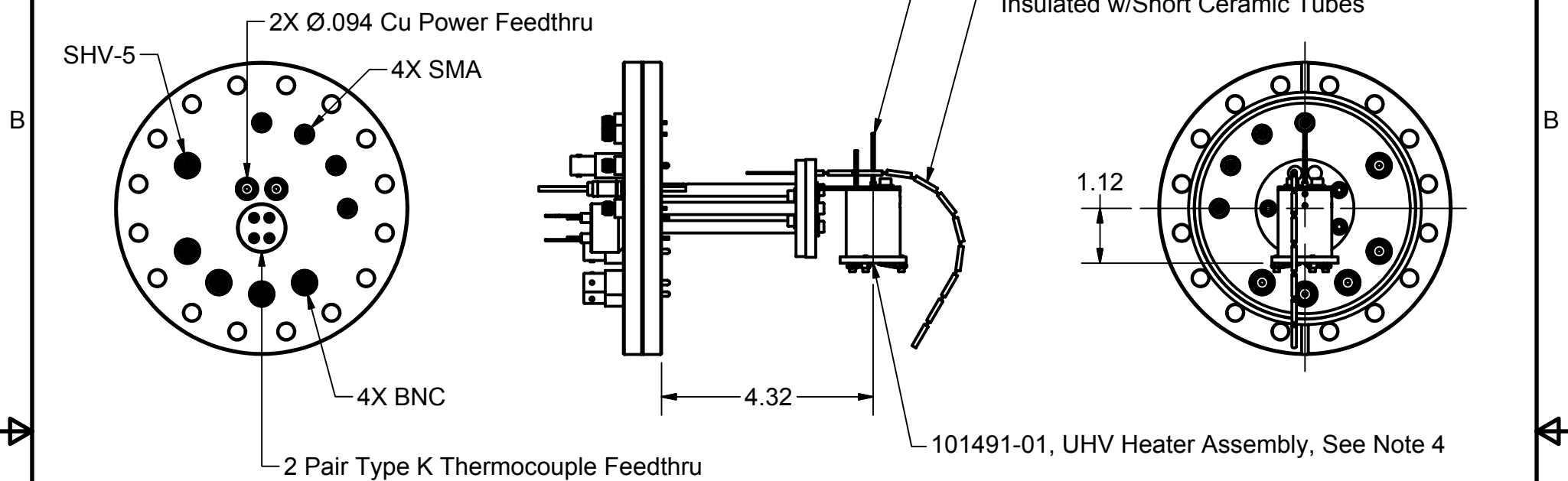

Notes:

1. All SST parts are electropolished for UHV use.
2. All vacuum side wiring is not shown for clarity.
3. Vacuum side is capable of 250°C service temperatures.
4. Heater has one lead internally grounded. The heater is common to the housing but isolated from the CFF.
5. Assembly must be leak tight to 1 x 10⁻⁹ cc/sec Helium.

This document is the property of HeatWave Labs. Its contents may not be reproduced without express written permission of HeatWave Labs.

DRAWN mcurtis	5/17/2011
CHECKED	
QA	
MFG	
APPROVED	
Material:	
-	

HeatWave Labs, Inc.
 195 Aviation Way, Suite 100 P: 831-722-9081
 Watsonville, CA 95076 F: 831-722-5491
 www.cathode.com

6 CFF Mounted 101491-01 Heater @ 90°

SIZE A	Cage Code: 1YAN4	DWG NO 106847	REV
SCALE 1/3	SHEET 1 OF 1		