

Dash #	Next Assembly
-	-

REV	DESCRIPTION	DATE	APPROVED

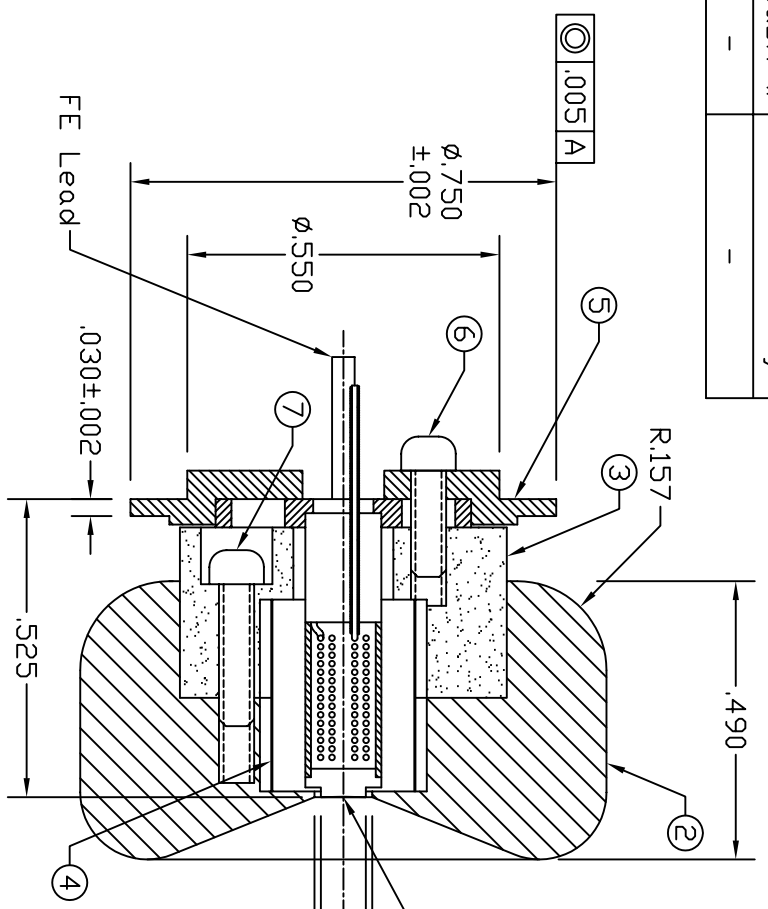

View A-A

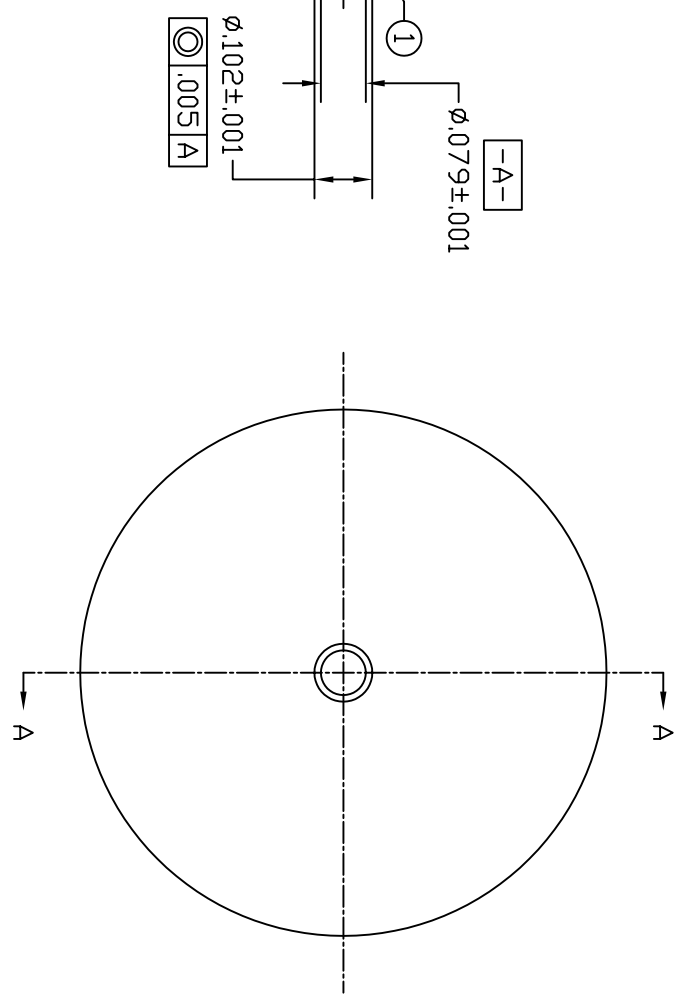

Notes:
1.

This document is the property of HeatWave Labs. Its contents may not be reproduced or distributed without express written permission of HeatWave Labs.

UNLESS OTHERWISE SPECIFIED ALL DIMENSIONS ARE IN INCHES. TOLERANCES ARE: XXXX = $\pm .005$ XX = $\pm .020$ FINISH 63 MICRONS ANGLES 0 DEGREE ± 30 MINUTES EDGES AND CORNERS .005 R MAX	MATERIAL -
--	---------------

Qty.	Part #	Description	Item #
2	-	#0-80 x 1/4 SST SHCS, Vented	7
2	-	#0-80 x 3/16 SST SHCS, Vented	6
1	103527	Weld Flange	5
1	103526	Heat Shield	4
1	103525	Insulator	3
1	103524	Focus Electrode	2
1	103523	Cathode Assembly	1

HeatWave Labs, Inc.
195 Aviation Way, Suite 100 (831) 722-9081
Watsonville, Ca. 95076 Fax: (831) 722-5491
Website: www.cathode.com

BY	DATE	Xenoc Cathode Assembly	SIZE A	Cage Code 1VAN4	DWG. NO. 103488	REV -
ENGR	M.Curtis					

DD NOT SCALE DRAWING
THIRD ANGLE PROJECTION
SCALE: 3x
SHEET: 1/1