

Dash #	Next Assembly
-	-

REVISIONS			
REV	DESCRIPTION	DATE	APPROVED
A	Added .030 R.	5/10/04	MC

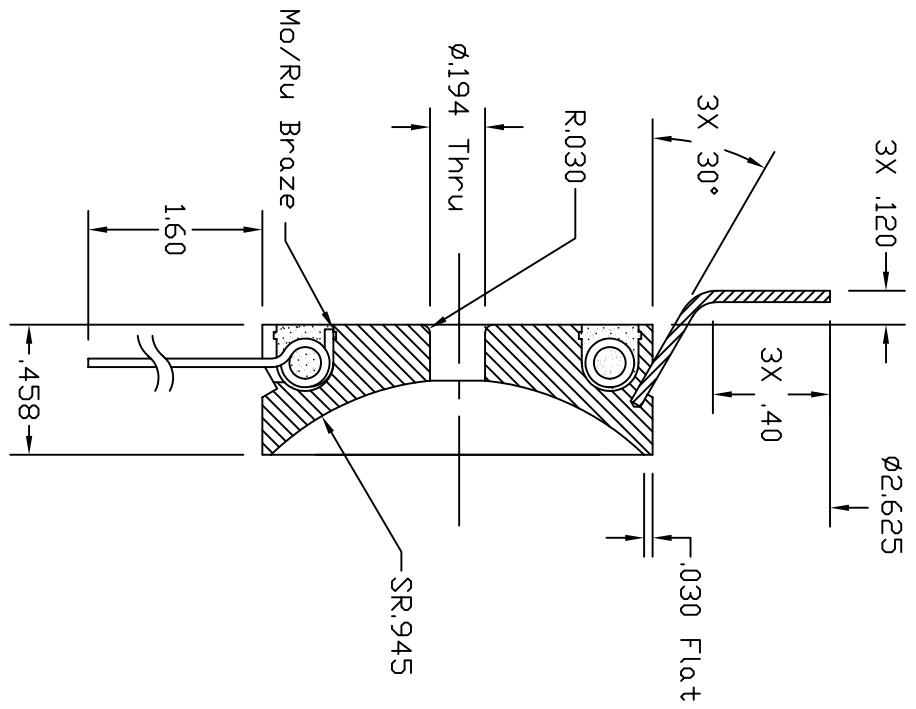

View A-A

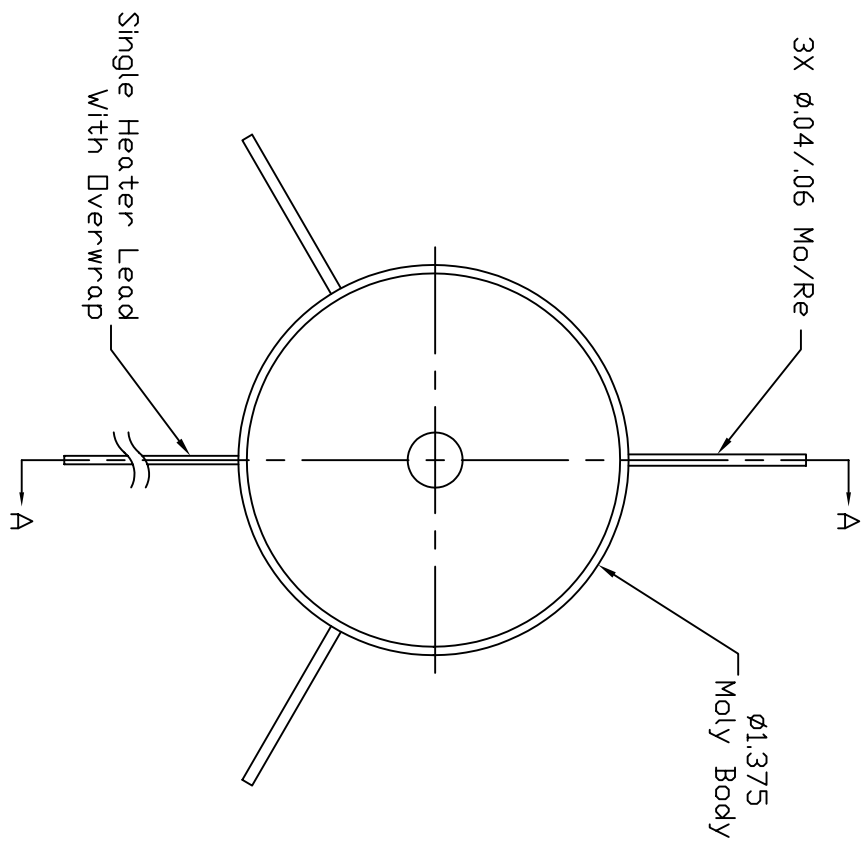

Notes:
1.

This document is the property of HeatWave Labs. Its contents may not be reproduced or distributed without express written permission of HeatWave Labs.

UNLESS OTHERWISE SPECIFIED ALL DIMENSIONS ARE IN INCHES. TOLERANCES ARE: XXX = ±.005 XX = ±.020 XXXX = ±.0005 FINISH 63 MICRONDINGERS ANGLES 0 DEGREE ±30 MINUTES EDGES AND CORNERS .005 R MAX
MATERIAL Noted
DD NOT SCALE DRAWING

Qty.	Part #	Description	Item #
		195 Aviation Way, Suite 100 (831) 722-9081 Watsonville, Ca. 95076 Fax: (831) 722-5491 Website: www.cathode.com	
HeatWave Labs, Inc.			
BY		DATE	
DRAWN	M.Curtis	4/8/02	
ENGR			
MATERIAL		Ø1.38 Ionizer Heater	
Noted		SIZE	REV
		FSCN ND.	A
		DWG. ND.	101869
		SCALE: 1.5X	SHEET: 1/1