

REVISIONS			
REV	DESCRIPTION	DATE	APPROVED

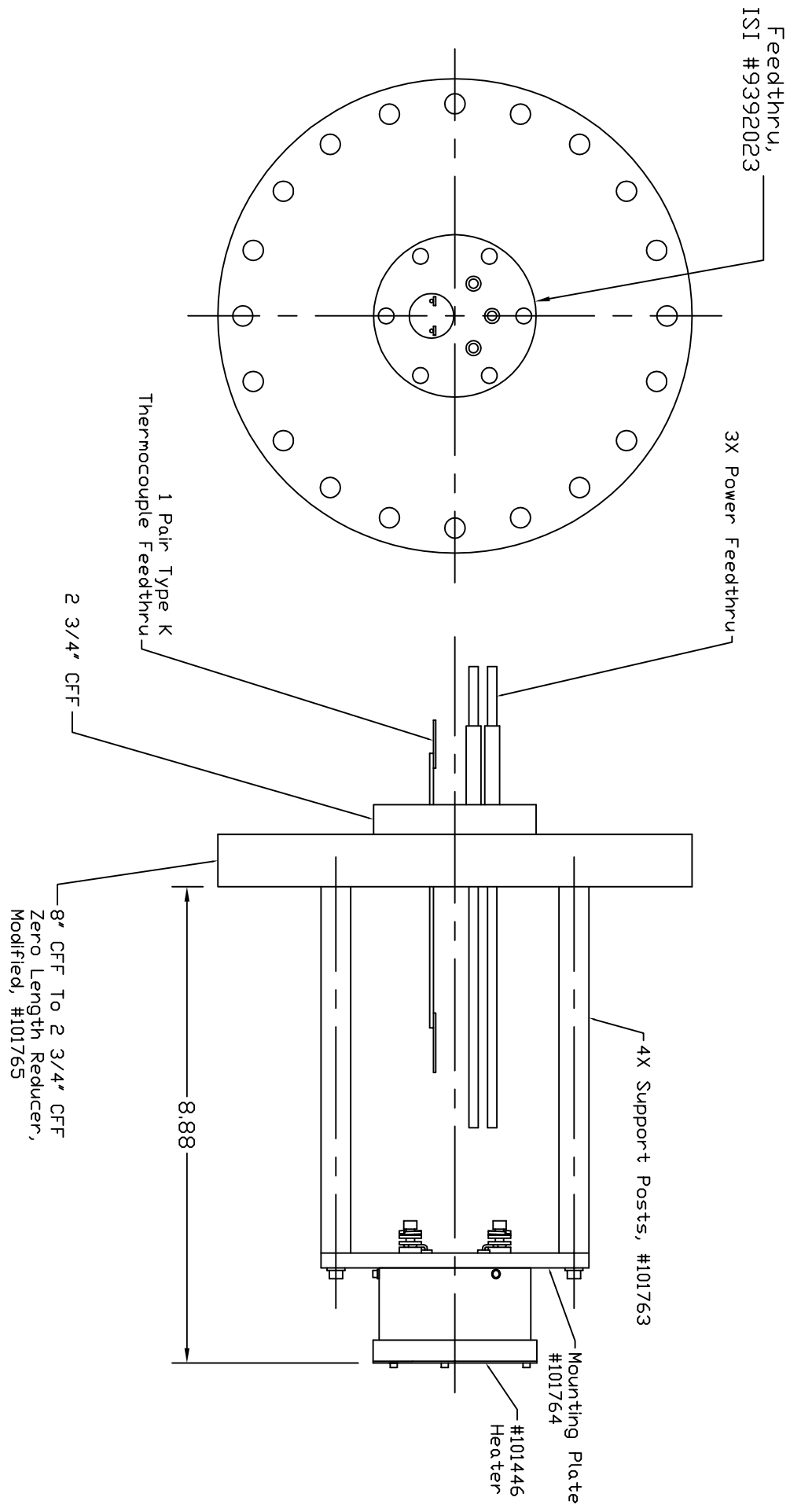

This document is the property of HeatWave Labs, Inc. Its contents may not be reproduced or distributed without express written permission of HeatWave Labs, Inc.

UNLESS OTHERWISE SPECIFIED
ALL DIMENSIONS ARE IN INCHES.
TOLERANCES ARE:
XXXX = ±.005 XX = ±.020
XXXXX = ±.0005
FINISH 63 MICRONDICHES
ANGLES 0 DEGREE ±30 MINUTES
EDGES AND CORNERS .005 R MAX

HeatWave Labs, Inc.

195 Aviation Way, Suite 100 (831) 722-9081
Watsonville, Ca. 95076 Fax: (831) 722-5491
Website: www.cathode.com

BY	DATE
ENGR M.Curtis	9/10/01

101446 Heater Mounted
On 8" CFF w/Feedthru

MATERIAL -
DD NOT SCALE DRAWING

SIZE A FSCN ND. DWG. ND. 101754 REV -
THIRD ANGLE PROJECTION SCALE: 0.4X SHEET: 1/1